

C.I.P.**10,3 Capra**

TAB. I

Date 18-05-16

Country of Origin: DE

Revision

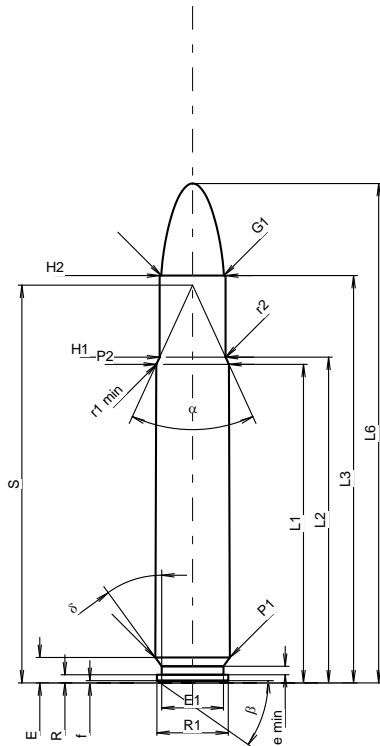
**CARTRIDGE MAXI****Lengths**

L1 ¹⁾	=	53.58	-0.20
L2 ¹⁾	=	54.78	-0.20
L3 ¹⁾	=	68.51	
L4	=		
L5	=	69.50	
L6	=	84.00	

Case Head

R	=	1.37	
R1	=	12.01	
R3	=		
E	=	4.27	
E1	=	10.39	
e min	=	1.40	
delta	=	36°	
f	=	0.38	
beta	=	35°	

Powder Chamber

P1	=	12.57	
P2 ¹⁾ *	=	12.20	-0.20

Junction Cone

alpha * ¹⁾	=	49°14'49"	
S ¹⁾	=	66.89	
r1 min	=	0.50	
r2	=	0.50	

Collar

H1	=	11.10	
H2	=	11.10	

Projectile

G1 ¹⁾	=	10.54	
G2	=		
F	=		
L3+G ¹⁾	=	98.51	

Pressures (Energies)**Method Transducer**

Pmax	=	4100 bar	
PK	=	4715 bar	
PE	=	5125 bar	
M	=	25.00	
EE	=	6500 Joule	

Miscellaneous Dimensions

Fe ¹⁾³⁾	=	0.10	
delta L	=		

CHAMBER MINI**Lengths**

L1	=	53.56	
L2	=	54.72	
L3 ¹⁾	=	68.80	

Breech

R	=	1.30	
R1	=	12.62	
R2	=		
R3	=		
r	=		

Powder Chamber

E	=	3.60	
P1 ¹⁾	=	12.60	
P2 * ¹⁾	=	12.23	

Junction Cone

alpha ¹⁾ *	=	49°31'08"	
S * ¹⁾	=	66.82	
r1 max	=	0.50	
r2	=	0.50	

Collar

H1 * ¹⁾	=	11.16	
H2 ¹⁾	=	11.11	

Commencement of Rifling

G1 ¹⁾ *	=	10.65	
G ¹⁾	=	30.00	
alpha l	=	180°	
h	=		
s	=		
i ¹⁾ *	=	0°22'55"	
w	=		

Barrel

F ¹⁾ *	=	10.25	
Z ¹⁾	=	10.49	

Grooves

b	=	3.60	
N	=	6	
u	=	450.00	
Q	=	85.16	mm ²

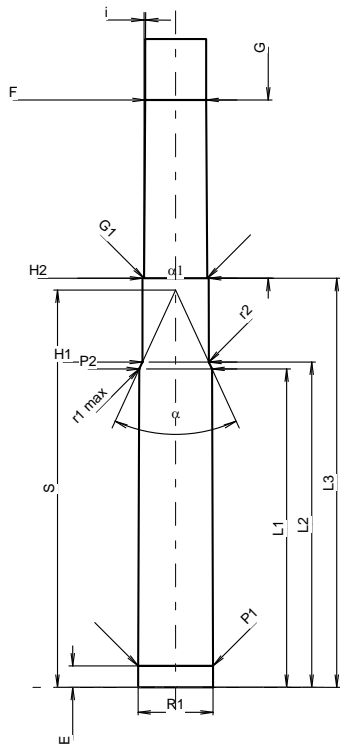

Scale 1:1.27

Dimensions in << mm >>
Dimensions and Tolerances for Proof Barrels
see Appendix CR 1.

Notes: 1) Check for safety reasons
3) Headspace on Shoulder
* Basic dimensions