

**C.I.P.****300 Precision Rifle Cartridge**

TAB. I

Datum 19-05-22

Revision 20-11-10

Ursprungsland: US

Alternative Namen: 300 PRC

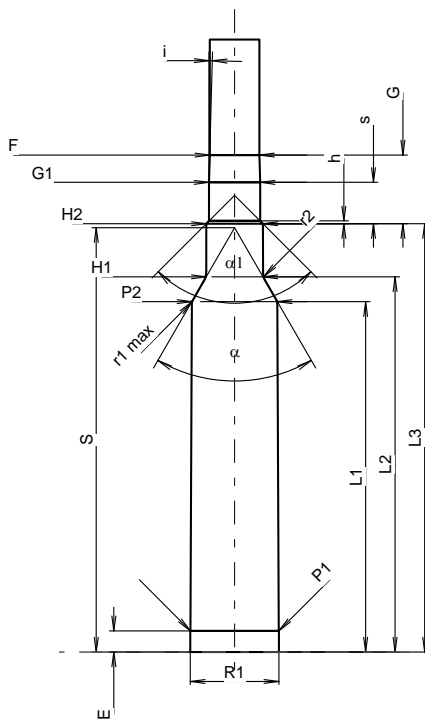
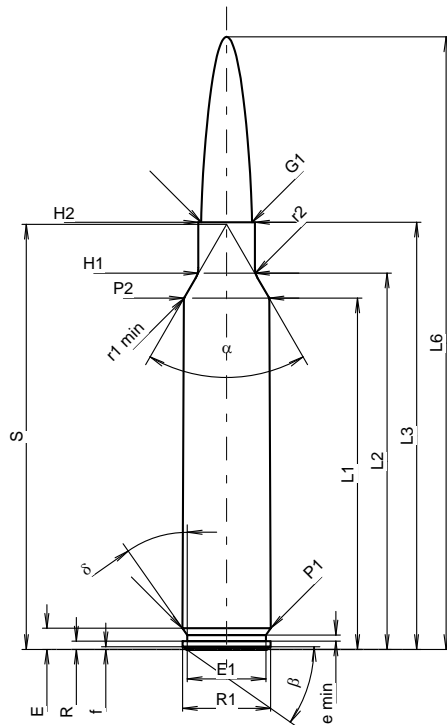

Maßstab 1:1.16

Maße in << mm >>  
Maße und Toleranzen für Messläufe  
siehe Anhang CR 1.

**PATRONE MAXI****Längen**

L1 <sup>1)</sup>	=	53.89	-0.20
L2 <sup>1)</sup>	=	57.72	-0.20
L3 <sup>1)</sup>	=	65.53	
L4	=		
L5	=		
L6	=	93.98	

**Hülsenboden**

R	=	1.27	
R1	=	13.51	
R3	=		
E	=	3.25	
E1	=	12.07	
e min	=	0.94	
delta	=	35°	
f	=	0.41	
beta	=	35°	

**Pulverkammer**

P1	=	13.53	
P2 <sup>1)</sup> *	=	13.08	-0.20

**Schulterkonus**

alpha <sup>*</sup>	=	60°	
S <sup>*</sup>	=	65.22	
r1 min	=	0.76	
r2	=	3.18	

**Hülsenhals**

H1 <sup>*</sup>	=	8.66	
H2 <sup>1)</sup>	=	8.66	

**Geschoss**

G1 <sup>1)</sup>	=	7.83	
G2	=		
F	=		
L3+G <sup>1)</sup>	=	76.07	

**Drücke (Energien)****Mech. elektr. Wandler**

Pmax	=	4400 bar	
PK	=	5060 bar	
PE	=	5500 bar	
M	=	25.00	
EE	=	5800 Joule	

**Verschiedene Daten**

Fe <sup>1)3)</sup>	=	0.10	
delta L	=	0.11	

**PATRONELAGER MINI****Längen**

L1	=	53.76	
L2	=	57.57	
L3 <sup>1)</sup>	=	65.72	

**Stoßboden**

R	=		
R1	=	13.58	
R2	=		
R3	=		
r	=		

**Pulverkammer**

E	=	3.25	
P1 <sup>1)</sup>	=	13.55	
P2 <sup>*</sup>	=	13.11	

**Schulterkonus**

alpha <sup>1)</sup> *	=	60°	
S <sup>*</sup>	=	65.11	
r1 max	=	0.76	
r2	=	3.18	

**Hülsenhals**

H1 <sup>*</sup>	=	8.71	
H2 <sup>1)</sup>	=	8.69	

**Geschossübergang**

G1 <sup>1)</sup> *	=	7.84	
G	=	10.54	
alpha l	=	90°	
h	=	0.43	
s <sup>*</sup>	=	6.34	
i <sup>1)</sup> *	=	1°30'	
w	=		

**Lauf**

F <sup>1)</sup> *	=	7.62	
Z <sup>1)</sup>	=	7.82	

**Züge**

b	=	2.92	
N	=	6	
u	=	216.00	
Q	=	47.40	mm <sup>2</sup>

Bemerkungen: 1) Kontrolle aus Sicherheitsgründen  
3) Verschlussabstand an Schulter  
\* Grundmaße