

C.I.P.**338 Win. Short Mag.**

TAB. I

Date 02-01-22

Revision 20-11-10

Country of Origin: US

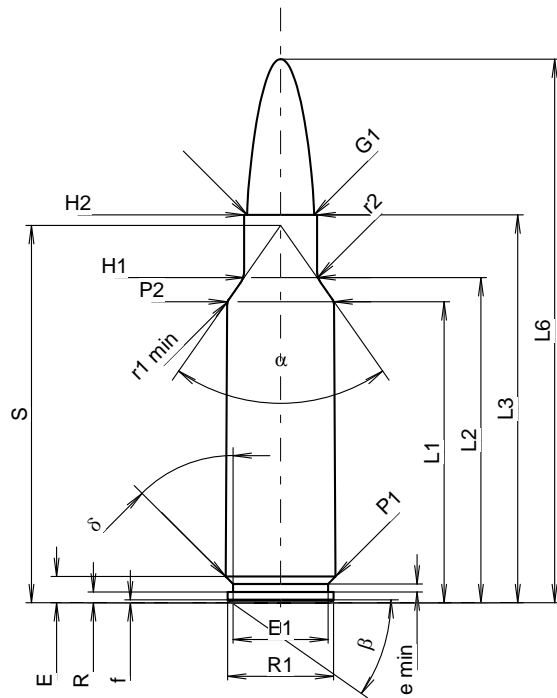
**CARTRIDGE MAXI****Lengths**

L1 ¹⁾	=	38.64	-0.20
L2 ¹⁾	=	41.74	-0.20
L3 ¹⁾	=	49.78	
L4	=		
L5	=		
L6	=	69.78	

Case Head

R	=	1.37	
R1	=	13.59	
R3	=		
E	=	3.35	
E1	=	12.19	
e min	=	1.02	
delta	=	45°	
f	=	0.36	
beta	=	35°	

Powder Chamber

P1	=	14.12	
P2 ¹⁾ *	=	13.71	-0.20

Junction Cone

alpha *	=	70°	
S *	=	48.43	
r1 min	=	1.27	
r2	=	2.54	

Collar

H1 *	=	9.37	
H2 ¹⁾	=	9.37	

Projectile

G1 ¹⁾	=	8.61	
G2	=		
F	=		
L3+G ¹⁾	=	57.39	

Pressures (Energies)**Method Transducer**

Pmax	=	4150 bar	
PK	=	4773 bar	
PE	=	5188 bar	
M	=	25.00	
EE	=	4935 Joule	

Miscellaneous Dimensions

Fe ¹⁾	=	0.10	
delta L	=	0.10	

CHAMBER MINI**Lengths**

L1	=	38.51	
L2	=	41.60	
L3 ¹⁾	=	50.04	

Breech

R	=		
R1	=	14.19	
R2	=		
R3	=		
r	=		

Powder Chamber

E	=	3.35	
P1 ¹⁾	=	14.15	
P2 *	=	13.75	

Junction Cone

alpha ¹⁾ *	=	70°	
S *	=	48.33	
r1 max	=	1.27	
r2	=	3.05	

Collar

H1 *	=	9.42	
H2 ¹⁾	=	9.40	

Commencement of Rifling

G1 ¹⁾ *	=	8.71	
G ¹⁾	=	7.61	
alpha 1 *	=	90°	
h	=	0.34	
s	=	2.89	
i ¹⁾ *	=	2°	
w	=		

Barrel

F ¹⁾ *	=	8.38	
Z ¹⁾	=	8.59	

Grooves

b	=	2.79	
N	=	6	
u	=	254.00	
Q	=	56.95	mm ²

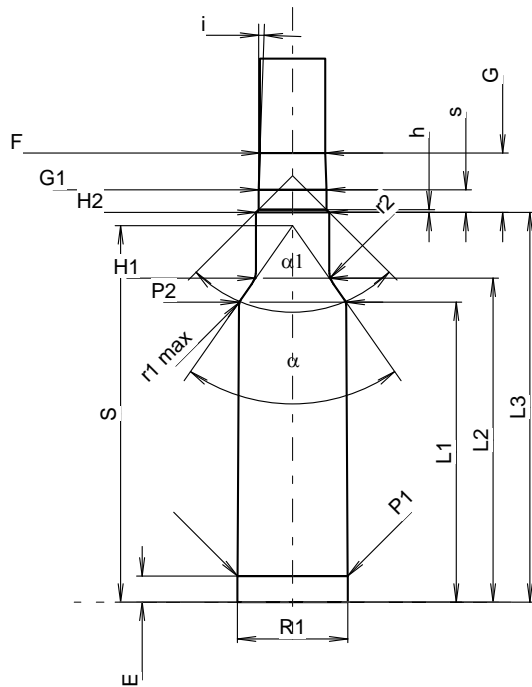

Scale 1.03:1

Dimensions in << mm >>
Dimensions and Tolerances for Proof Barrels
see Appendix CR 1.

Notes: 1) Check for safety reasons
* Basic dimensions