

**C.I.P.****6,5 x 52 Carcano**

TAB.

I

Date

93-09-21

Révision

14-05-20

Pays d'origine: IT

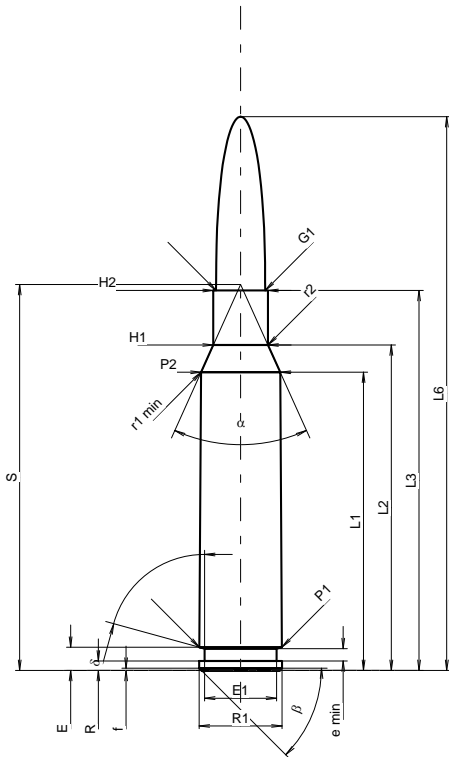
**CARTOUCHE MAXI****Longueurs**

L1 <sup>1)*</sup>	=	41.20	-0.20
L2 <sup>1)*</sup>	=	44.96	-0.20
L3 <sup>1)</sup>	=	52.50	
L4	=		
L5	=		
L6	=	76.50	

**Culot**

R	=	1.30	
R1	=	11.45	
R3	=		
E	=	3.20	
E1	=	9.95	
e min	=	1.70	
delta	=	74°40'48"	
f	=	0.30	
beta	=	45°	

**Chambre à poudre**

P1	=	11.41	
P2 <sup>1)*</sup>	=	10.94	-0.20

**Cône de raccordement**

alpha	=	48°31'53"	
S	=	53.33	
r1 min	=	3.00	
r2	=	2.25	

**Collet**

H1 *	=	7.55	
H2 <sup>1)</sup>	=	7.55	

**Projectile**

G1 <sup>1)</sup>	=	6.80	
G2	=		
F	=		
L3+G <sup>1)</sup>	=	76.90	

**Pressions (Énergies)****Méthode transducteur**

Pmax	=	2850 bar	
PK	=	3278 bar	
PE	=	3560 bar	
M	=	25.00	
EE	=	2465 Joule	

**Autres indications**

Fe <sup>1)3)</sup>	=	0.15	
delta L	=	0.05	

**CHAMBRE MINI****Longueurs**

L1 *	=	41.15	
L2 *	=	44.89	
L3 <sup>1)</sup>	=	53.00	

**Cuvette**

R	=		
R1	=	11.50	
R2	=		
R3	=		
r	=		

**Chambre à poudre**

E	=	3.20	
P1 <sup>1)</sup>	=	11.46	
P2 *	=	10.95	

**Cône de raccordement**

alpha <sup>1)</sup>	=	48°38'1"	
S	=	53.27	
r1 max	=	3.00	
r2	=	2.25	

**Collet**

H1 *	=	7.57	
H2 <sup>1)</sup>	=	7.55	

**Prise de rayures**

G1 <sup>1)*</sup>	=	6.80	
G <sup>1)*</sup>	=	24.40	
alpha l	=	8°34'41"	
h	=	5.00	
s *	=	19.40	
i <sup>1)</sup>	=	1°43'6"	
w	=		

**Canon**

F <sup>1)*</sup>	=	6.50	
Z <sup>1)</sup>	=	6.80	

**Rayures**

b	=	3.00	
N	=	4	
u	=	201.50	
Q	=	35.05	mm <sup>2</sup>

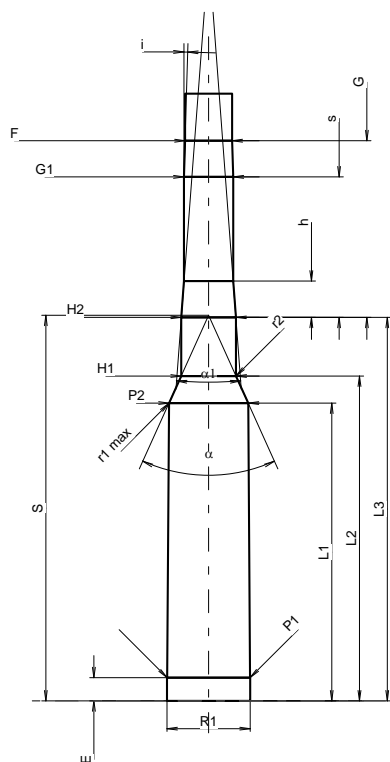

Échelle 1:1.04

Dimensions en << mm >>  
Dimensions et tolérances pour les canons  
d'épreuve: Voyez Annexe CR 1.

Notes: 1) A' contrôler pour la sécurité  
3) Feuillure sur la cone de raccordement  
\* Dimensions de base