

C.I.P.

6 mm Advanced Rifle Cartridge

TAB.	I
Date	20-11-10
Revision	24-05-14

Country of Origin: US

Alternative Names: 6 mm ARC

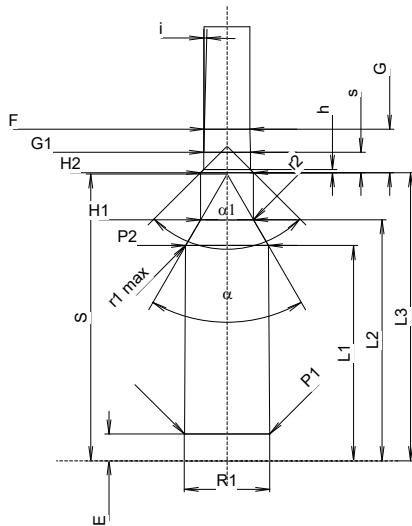
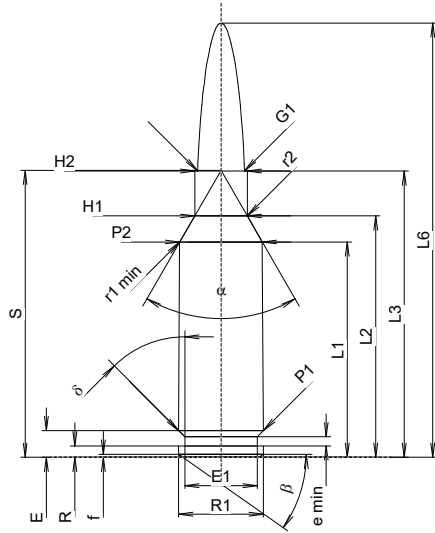

Scale 1:1

Dimensions in << mm >>
Dimensions and Tolerances for Proof Barrels
see Appendix CR 1.

CARTRIDGE MAXI

Lengths

L1 ¹⁾	=	28.47	-0.20
L2 ¹⁾	=	31.90	-0.20
L3 ¹⁾	=	37.85	
L4	=		
L5	=		
L6	=	57.40	

Case Head

R	=	1.50	
R1	=	11.20	
R3	=		
E	=	3.52	
E1	=	9.55	
e min	=	1.19	
delta	=	45°	
f	=	0.38	
beta	=	35°	

Powder Chamber

P1	=	11.20	
P2 ¹⁾ *	=	10.92	-0.20

Junction Cone

alpha *	=	60°	
S *	=	37.93	
r1 min	=	0.76	
r2	=	3.18	

Collar

H1 *	=	6.96	
H2 ¹⁾	=	6.96	

Projectile

G1 ¹⁾	=	6.18	
G2	=		
F	=		
L3+G ¹⁾	=	43.59	

Pressures (Energies)

Method Transducer

Pmax	=	3800 bar	
PK	=	4370 bar	
PE	=	4750 bar	
M	=	17.50	
EE	=	2600 Joule	

Miscellaneous Dimensions

Fe ¹⁾³⁾	=	0.10	
delta L	=		

CHAMBER MINI

Lengths

L1	=	28.45	
L2	=	31.88	
L3 ¹⁾	=	38.10	

Breech

R	=		
R1	=	11.31	
R2	=		
R3	=		
r	=		

Powder Chamber

E	=	3.52	
P1 ¹⁾	=	11.26	
P2 *	=	10.95	

Junction Cone

alpha ¹⁾	=	60°	
S *	=	37.93	
r1 max	=	0.76	
r2	=	3.18	

Collar

H1 *	=	6.99	
H2 ¹⁾	=	6.99	

Commencement of Rifling

G1 ¹⁾ *	=	6.18	
G ¹⁾	=	5.74	
alpha1 *	=	90°	
h	=	0.41	
s	=	2.68	
i ¹⁾ *	=	1°30'	
w	=		

Barrel

F ¹⁾ *	=	6.02	
Z ¹⁾	=	6.17	

Grooves

b	=	2.29	
N	=	6	
u	=	191.00	mm ²
Q	=	29.52	mm ²

Notes: 1) Check for safety reasons
3) Headspace on Shoulder
* Basic dimensions