

**C.I.P.****6 mm Creedmoor**

TAB. I

Date 19-05-22

Revision 21-11-09

Country of Origin: US

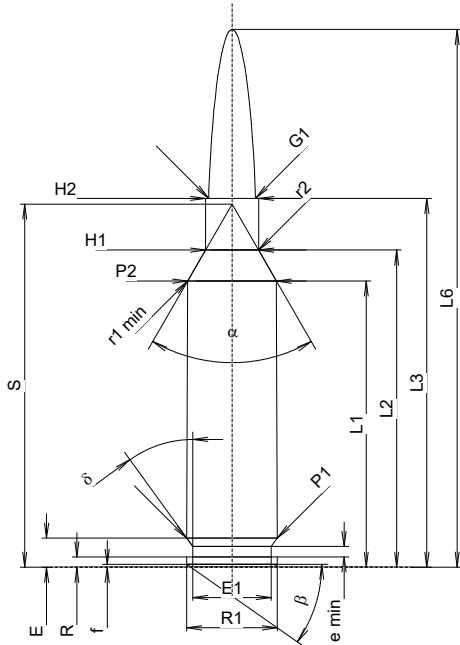
**CARTRIDGE MAXI****Lengths**

L1 <sup>1)</sup>	=	37.84	-0.20
L2 <sup>1)</sup>	=	41.94	-0.20
L3 <sup>1)</sup>	=	48.77	
L4	=		
L5	=		
L6	=	71.12	

**Case Head**

R	=	1.37	
R1	=	11.99	
R3	=		
E	=	3.85	
E1	=	10.39	
e min	=	1.40	
delta	=	36°	
f	=	0.38	
beta	=	35°	

**Powder Chamber**

P1	=	11.96	
P2 <sup>1)</sup> *	=	11.74	-0.20

**Junction Cone**

alpha *	=	60°	
S *	=	48.00	
r1 min	=	0.76	
r2	=	3.18	

**Collar**

H1 *	=	7.01	
H2 <sup>1)</sup>	=	7.01	

**Projectile**

G1 <sup>1)</sup>	=	6.18	
G2	=		
F	=		
L3+G <sup>1)</sup>	=	56.99	

**Pressures (Energies)****Method Transducer**

Pmax	=	4350 bar	
PK	=	5003 bar	
PE	=	5438 bar	
M	=	25.00	
EE	=	3200 Joule	

**Miscellaneous Dimensions**

Fe <sup>1)3)</sup>	=	0.10	
delta L	=	0.06	

**CHAMBER MINI****Lengths**

L1	=	37.76	
L2	=	41.85	
L3 <sup>1)</sup>	=	48.90	

**Breech**

R	=		
R1	=	12.01	
R2	=		
R3	=		
r	=		

**Powder Chamber**

E	=	3.85	
P1 <sup>1)</sup>	=	11.98	
P2 *	=	11.76	

**Junction Cone**

alpha <sup>1)</sup> *	=	60°	
S *	=	47.95	
r1 max	=	0.76	
r2	=	3.18	

**Collar**

H1 *	=	7.04	
H2 <sup>1)</sup>	=	7.04	

**Commencement of Rifling**

G1 <sup>1)</sup> *	=	6.19	
G	=	8.22	
alpha 1	=	90°	
h	=	0.43	
s *	=	5.07	
i <sup>1)</sup> *	=	1°30'	
w	=		

**Barrel**

F <sup>1)</sup> *	=	6.02	
Z <sup>1)</sup>	=	6.17	

**Grooves**

b	=	2.29	
N	=	6	
u	=	191.00	
Q	=	29.52	mm <sup>2</sup>

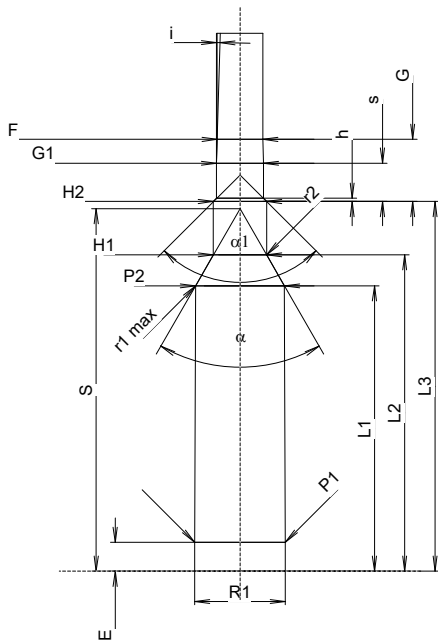

Scale 1:1

Dimensions in << mm >>  
Dimensions and Tolerances for Proof Barrels  
see Appendix CR 1.

Notes: 1) Check for safety reasons  
3) Headspace on Shoulder  
\* Basic dimensions