

C.I.P.**6 mm Dasher**

TAB.

I

Date

23-05-09

Country of Origin: US

Revision

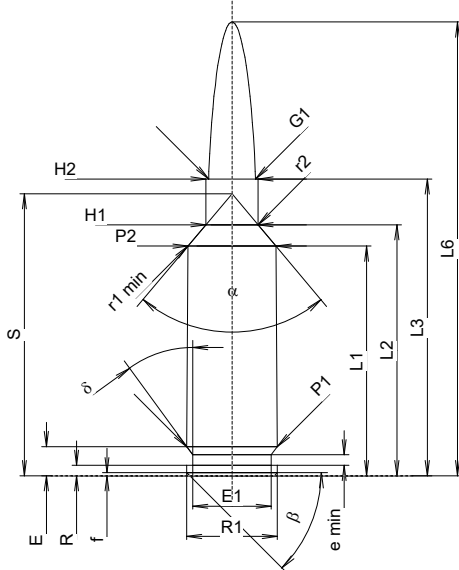
**CARTRIDGE MAXI****Lengths**

L1 ¹⁾ *	=	30.37	-0.20
L2 ¹⁾ *	=	33.20	-0.20
L3 ¹⁾	=	39.24	
L4	=		
L5	=		
L6	=	60.00	

Case Head

R	=	1.37	
R1	=	12.01	
R3	=		
E	=	3.85	
E1	=	10.39	
e min	=	1.40	
delta	=	36°	
f	=	0.40	
beta	=	45°	

Powder Chamber

P1	=	11.96	
P2 ¹⁾ *	=	11.65	-0.20

Junction Cone

alpha *	=	80°	
S *	=	37.31	
r1 min	=	0.64	
r2	=	1.10	

Collar

H1 *	=	6.90	
H2 ¹⁾	=	6.88	

Projectile

G1 ¹⁾	=	6.18	
G2	=		
F	=		
L3+G ¹⁾	=	45.22	

Pressures (Energies)**Method Transducer**

Pmax	=	4400 bar	
PK	=	5060 bar	
PE	=	5500 bar	
M	=	17.50	
EE	=	2200 Joule	

Miscellaneous Dimensions

Fe ¹⁾³⁾	=	0.10	
delta L	=		

CHAMBER MINI**Lengths**

L1 *	=	30.42	
L2 *	=	33.26	
L3 ¹⁾	=	39.55	

Breech

R	=		
R1	=	12.04	
R2	=		
R3	=		
r	=		

Powder Chamber

E	=	3.85	
P1 ¹⁾	=	11.99	
P2 *	=	11.68	

Junction Cone

alpha ¹⁾	=	80°	
S	=	37.37	
r1 max	=	0.64	
r2	=	1.52	

Collar

H1 *	=	6.91	
H2 ¹⁾	=	6.89	

Commencement of Rifling

G1 ¹⁾ *	=	6.19	
G ¹⁾	=	5.98	
alpha 1	=	90°	
h	=	0.35	
s *	=	2.74	
i ¹⁾ *	=	1°30'	
w	=		

Barrel

F ¹⁾ *	=	6.02	
Z ¹⁾ *	=	6.17	

Grooves

b	=	2.29	
N	=	6	
u	=	196.85	
Q	=	29.52	mm ²

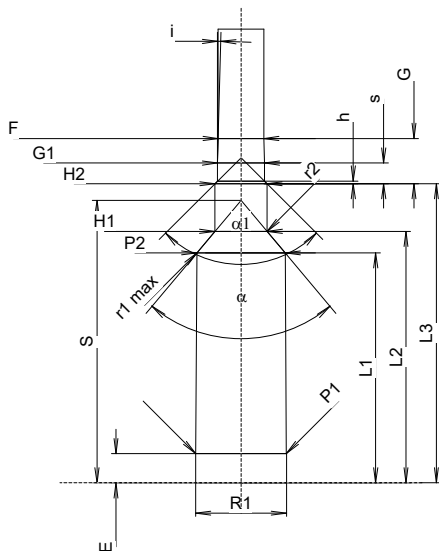

Scale 1:1

Dimensions in << mm >>
Dimensions and Tolerances for Proof Barrels
see Appendix .

Notes: 1) Check for safety reasons
3) Headspace on Shoulder
* Basic dimensions