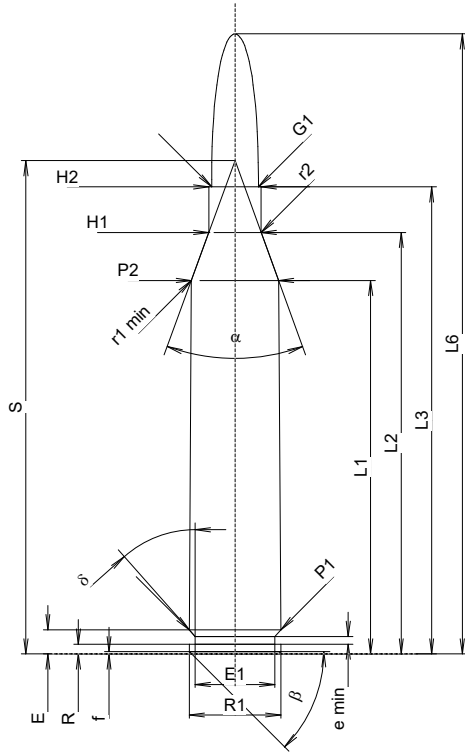

C.I.P.**6 x 62 Freres**

Pays d'origine: DE

TAB.**I****Date****84-06-14****Révision****22-04-26****CARTOUCHE MAXI****Longueurs**

L1 ¹⁾ *	=	49.40	-0.20
L2 ¹⁾ *	=	55.75	-0.20
L3 ¹⁾	=	61.75	
L4	=		
L5	=		
L6	=	82.00	

Culot

R	=	1.30	
R1	=	12.10	
R3	=		
E	=	3.20	
E1	=	10.50	
e min	=	1.00	
δ	=	41.630000°	
f	=	0.30	
β	=	45°	

Chambre à poudre

P1	=	12.10	
P2 ¹⁾ *	=	11.53	-0.20

Cône de raccordement

α	=	39°58'51"	
S	=	65.25	
r1 min	=	0.50	
r2	=	0.50	

Collet

H1 *	=	6.91	
H2 ¹⁾	=	6.91	

Projectile

G1 ¹⁾	=	6.18	
G2	=		
F	=		
L3+G ¹⁾	=	68.42	

Pressions (Énergies)**Méthode transducteur**

Pmax	=	4300 bar	
PK	=	4945 bar	
PE	=	5375 bar	
M	=	25.00	
EE	=	3300 Joule	

Autres indications

Fe ¹⁾	=	0.10	
delta L	=	0.12	

CHAMBRE MINI**Longueurs**

L1 *	=	49.26	
L2 *	=	55.58	
L3 ¹⁾	=	62.00	

Cuvette

R	=	1.30	
R1	=	12.12	
R2	=		
R3	=		
r	=		

Chambre à poudre

E	=	3.20	
P1 ¹⁾	=	12.12	
P2 *	=	11.55	

Cône de raccordement

α ¹⁾	=	39°59'43"	
S	=	65.13	
r1 max	=	0.50	
r2	=	0.50	

Collet

H1 *	=	6.95	
H2 ¹⁾	=	6.93	

Prise de rayures

G1 ¹⁾ *	=	6.19	
G ¹⁾ *	=	6.67	
α1	=	180°	
h	=		
s *	=	2.97	
i ¹⁾	=	1°19'36"	
w	=		

Canon

F ¹⁾ *	=	6.02	
Z ¹⁾	=	6.17	

Rayures

b	=	1.73	
N	=	6	
u	=	260.00	
Q	=	29.25	mm ²

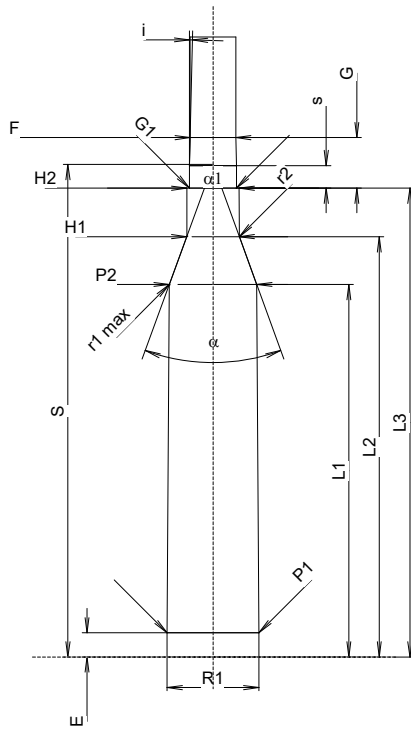

Échelle 1:1

Dimensions en << mm >>
Dimensions et tolérances pour les canons
d'épreuve: Voyez Annexe CR 1.

Notes: 1) A' contrôler pour la sécurité
* Dimensions de base