

C.I.P.**666T**

TAB.

I

Date

22-04-26

Pays d'origine: TR

Révision

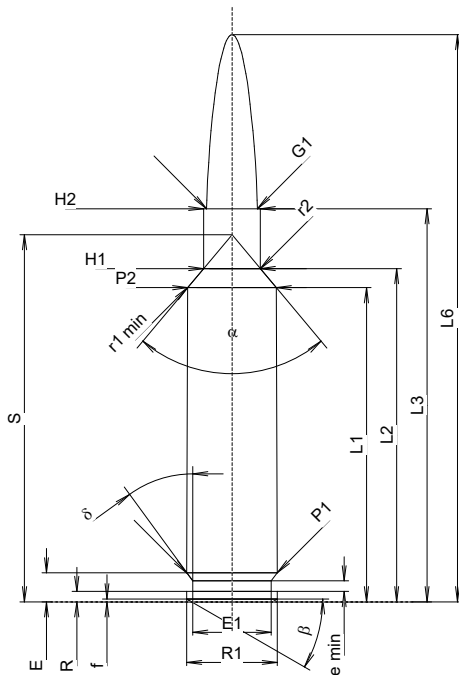
**CARTOUCHE MAXI****Longueurs**

L1	=	41.55	-0.20
L2	=	44.08	-0.20
L3	=	52.00	
L4	=		
L5	=		
L6	=	75.00	

Culot

R	=	1.37	
R1	=	12.01	
R3	=		
E	=	3.85	
E1	=	10.39	
e min	=	1.40	
delta	=	36°	
f	=	0.38	
beta	=	30°	

Chambre à poudre

P1	=	11.96	
P2	=	11.73	

Cône de raccordement

alpha	=	80°	
S	=	48.55	
r1 min	=	0.76	
r2	=	3.18	

Collet

H1	=	7.49	
H2	=	7.49	

Projectile

G1	=	6.72	
G2	=		
F	=		
L3+G	=	61.65	

Pressions (Énergies)**Méthode transducteur**

Pmax	=	4350 bar	
PK	=	5003 bar	
PE	=	5438 bar	
M	=	25.00	
EE	=	3400 Joule	

Autres indications

Fe	=	0.10	
delta L	=	0.15	

CHAMBRE MINI**Longueurs**

L1	=	41.38	
L2	=	43.90	
L3	=	52.20	

Cuvette

R	=		
R1	=	12.03	
R2	=		
R3	=		
r	=		

Chambre à poudre

E	=	3.85	
P1	=	11.98	
P2	=	11.76	

Cône de raccordement

alpha	=	80°	
S	=	48.40	
r1 max	=	0.76	
r2	=	3.68	

Collet

H1	=	7.54	
H2	=	7.52	

Prise de rayures

G1	=	6.72	
G	=	9.65	
alpha1	=	90°	
h	=	0.40	
s	=	5.45	
i	=	1°30'	
w	=		

Canon

F	=	6.50	
Z	=	6.71	

Rayures

b	=	2.14	
N	=	6	
u	=		
Q	=	34.56	mm ²

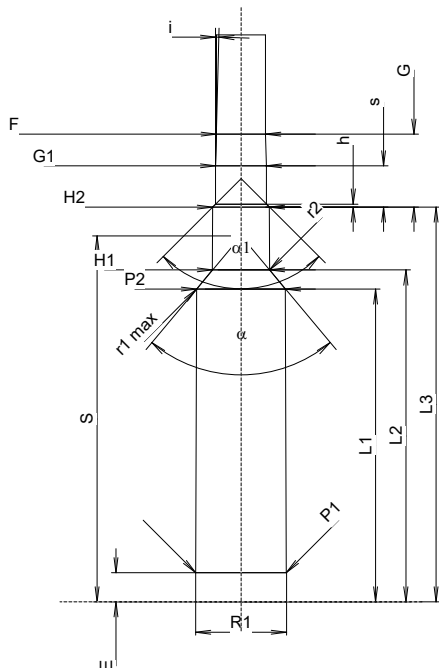

Échelle 1:1

Dimensions en << mm >>
Dimensions et tolérances pour les canons
d'épreuve: Voyez Annexe .

Notes: