

**C.I.P.****325 WSM**

TAB.

I

Datum

07-05-14

Revision

Ursprungsland: US

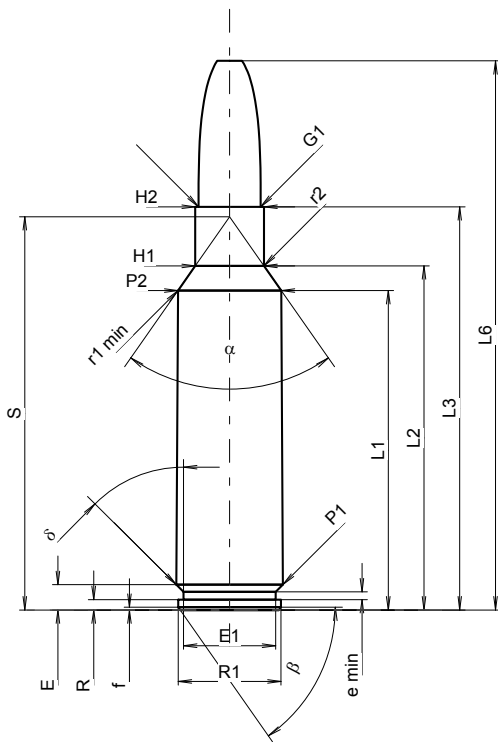
**PATRONE MAXI****Längen**

L1 <sup>1)</sup>	=	42.25	-0.20
L2 <sup>1)</sup>	=	45.52	-0.20
L3 <sup>1)</sup>	=	53.34	
L4	=		
L5	=		
L6	=	72.64	

**Hülsenboden**

R	=	1.37	
R1	=	13.59	
R3	=		
E	=	3.35	
E1	=	12.19	
e min	=	1.02	
delta	=	45°	
f	=	0.36	
beta	=	55°	

**Pulverkammer**

P1	=	14.12	
P2 <sup>1)</sup> *	=	13.67	-0.20

**Schulterkonus**

alpha *	=	70°	
S *	=	52.01	
r1 min	=	1.27	
r2	=	2.54	

**Hülsenhals**

H1 *	=	9.09	
H2 <sup>1)</sup>	=	9.09	

**Geschoss**

G1 <sup>1)</sup>	=	8.22	
G2	=		
F	=		
L3+G <sup>1)</sup>	=	63.58	

**Drücke (Energien)****Mech. elektr. Wandler**

Pmax	=	4350 bar	
PK	=	5000 bar	
PE	=	5430 bar	
M	=	25.00	
EE	=	5100 Joule	

**Verschiedene Daten**

Fe <sup>1)3)</sup>	=	0.10	
delta L	=	0.11	

**PATRONENLAGER MINI****Längen**

L1	=	42.12	
L2	=	45.38	
L3 <sup>1)</sup>	=	53.59	

**Stoßboden**

R	=		
R1	=	14.19	
R2	=		
R3	=		
r	=		

**Pulverkammer**

E	=	3.35	
P1 <sup>1)</sup>	=	14.15	
P2 *	=	13.70	

**Schulterkonus**

alpha <sup>1)</sup> *	=	70°	
S *	=	51.91	
r1 max	=	1.27	
r2	=	3.05	

**Hülsenhals**

H1 *	=	9.14	
H2 <sup>1)</sup>	=	9.12	

**Geschossübergang**

G1 <sup>1)</sup> *	=	8.26	
G <sup>1)</sup>	=	10.24	
alpha1 *	=	90°	
h	=	0.43	
s	=	5.28	
i <sup>1)</sup> *	=	1°30'	
w	=		

**Lauf**

F <sup>1)</sup> *	=	8.00	
Z <sup>1)</sup>	=	8.20	

**Züge**

b	=	4.47	
N	=	4	
u	=	254.00	
Q	=	52.16	mm <sup>2</sup>

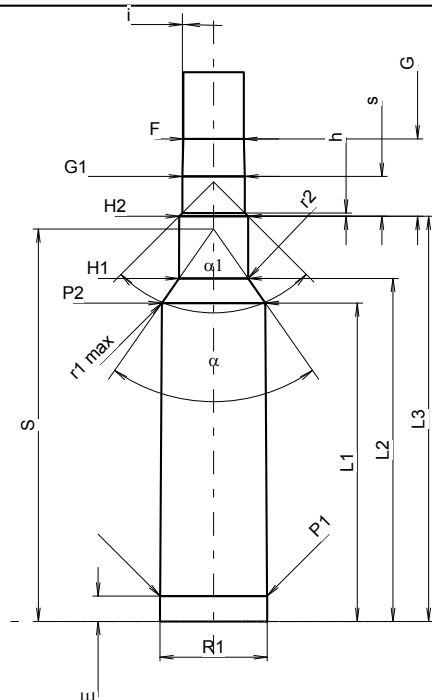

Maßstab 1:1

Maße in << mm >>  
Maße und Toleranzen für Messläufe  
siehe Anhang CR 1.

Bemerkungen: 1) Kontrolle aus Sicherheitsgründen  
3) Verschlussabstand an Schulter  
\* Grundmaße