

C.I.P.**8 x 64 S**

TAB. I

Datum 84-06-14

Revision 02-05-15

Ursprungsland: DE

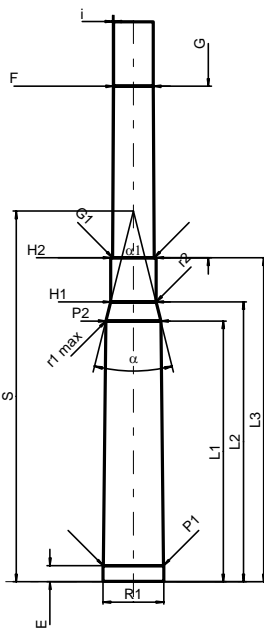
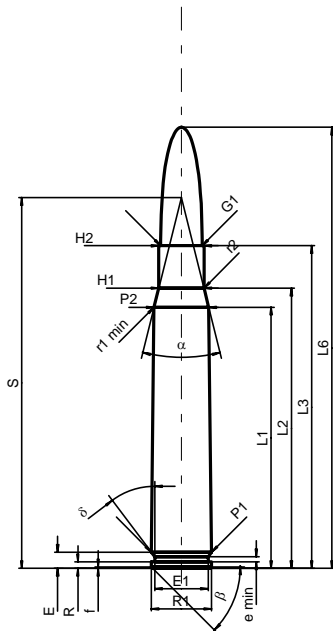

Maßstab 1:1.5

Maße in << mm >>
Maße und Toleranzen für Messläufe
siehe Anhang CR 1.

PATRONE MAXI**Längen**

L1 ¹⁾ *	=	51.80	-0.20
L2 ¹⁾ *	=	55.59	-0.20
L3 ¹⁾	=	64.00	
L4	=		
L5	=	67.10	
L6	=	87.50	

Hülsenboden

R	=	1.30	
R1	=	12.00	
R3	=		
E	=	3.20	
E1	=	10.60	
e min	=	1.00	
delta	=	36°48'	
f	=	0.30	
beta	=	45°	

Pulverkammer

P1	=	11.95	
P2 ¹⁾ *	=	10.85	-0.20

Schulterkonus

alpha	=	28°00'05"	
S	=	73.56	
r1 min	=	0.50	
r2	=	0.50	

Hülsenhals

H1 *	=	8.96	
H2 ¹⁾	=	8.96	

Geschoss

G1 ¹⁾	=	8.22	
G2	=	8.18	
F	=		
L3+G ¹⁾	=	98.00	

Drücke (Energien)**Mech. elektr. Wandler**

Pmax	=	4050 bar	
PK	=	4658 bar	
PE	=	5060 bar	
M	=	25.00	
EE	=	4595 Joule	

Verschiedene Daten

Fe ¹⁾	=	0.10	
delta L	=		

PATRONENLAGER MINI**Längen**

L1 *	=	51.74	
L2 *	=	55.53	
L3 ¹⁾	=	64.30	

Stoßboden

R	=	1.30	
R1	=	12.05	
R2	=		
R3	=		
r	=		

Pulverkammer

E	=	3.20	
P1 ¹⁾	=	11.98	
P2 *	=	10.88	

Schulterkonus

alpha ¹⁾	=	28°00'05"	
S	=	73.56	
r1 max	=	0.50	
r2	=	0.50	

Hülsenhals

H1 *	=	8.99	
H2 ¹⁾	=	8.98	

Geschossübergang

G1 ¹⁾ *	=	8.23	
G ¹⁾ *	=	34.00	
alpha1	=	180°	
h	=		
s	=		
i ¹⁾	=	0°17'11"	
w	=		

Lauf

F ¹⁾ *	=	7.89	
Z ¹⁾	=	8.20	

Züge

b	=	4.40	
N	=	4	
u	=	240.00	
Q	=	51.78	mm ²

Bemerkungen: 1) Kontrolle aus Sicherheitsgründen
* Grundmaße