

C.I.P.**280 Riml. N. E. Ross**

TAB. I

Date 84-06-14

Revision 02-05-15

Country of Origin: GB

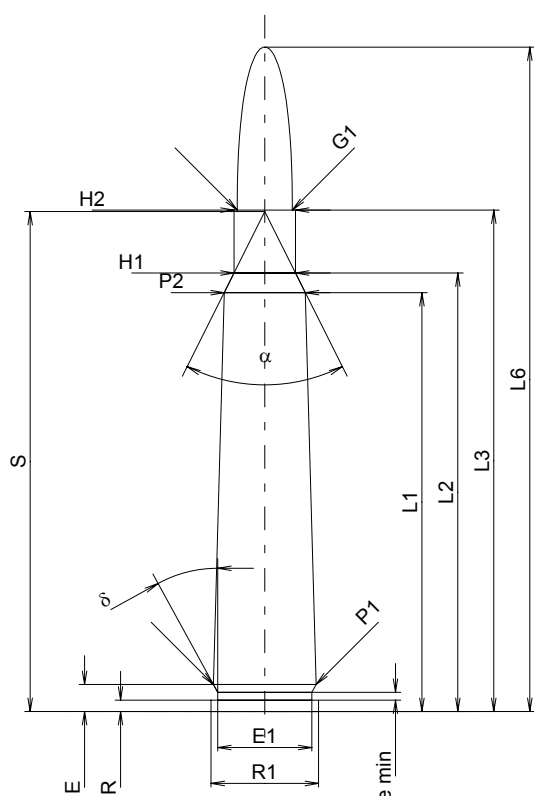
**CARTRIDGE MAXI****Lengths**

L1 ¹⁾	=	55.40	-0.20
L2 ¹⁾	=	57.99	-0.20
L3 ¹⁾	=	66.32	
L4	=		
L5	=		
L6	=	87.88	

Case Head

R	=	1.52	
R1	=	14.22	
R3	=		
E	=	3.58	
E1	=	12.45	
e min	=	1.02	
delta	=	28°43'48"	
f	=		
beta	=		

Powder Chamber

P1	=	13.59	
P2 ¹⁾ *	=	10.72	-0.20

Junction Cone

alpha	=	53°07'48"	
S	=	66.12	
r1 min	=		
r2	=		

Collar

H1*	=	8.13	
H2 ¹⁾	=	8.13	

Projectile

G1 ¹⁾	=	7.29	
G2	=		
F	=		
L3+G ¹⁾	=	72.27	

Pressures (Energies)**Method Transducer**

Pmax	=	3250 bar	
PK	=	3738 bar	
PE	=	4060 bar	
M	=	25.00	
EE	=	4440 Joule	

Miscellaneous Dimensions

Fe ¹⁾	=	0.15	
delta L	=		

CHAMBER MINI**Lengths**

L1*	=	55.35	
L2*	=	57.94	
L3 ¹⁾	=	66.62	

Breech

R	=	1.52	
R1	=	14.27	
R2	=		
R3	=		
r	=		

Powder Chamber

E	=	3.58	
P1 ¹⁾	=	13.61	
P2*	=	10.74	

Junction Cone

alpha ¹⁾	=	53°07'48"	
S	=	66.09	
r1 max	=		
r2	=		

Collar

H1*	=	8.15	
H2 ¹⁾	=	8.15	

Commencement of Rifling

G1 ¹⁾ *	=	7.34	
G ¹⁾ *	=	5.95	
alpha1	=	90°	
h*	=	0.41	
s	=		
i ¹⁾	=	1°29'57"	
w	=		

Barrel

F ¹⁾ *	=	7.05	
Z ¹⁾	=	7.30	

Grooves

b	=		
N	=		
u	=	220.00	
Q	=	39.04	mm ²

Scale 1:1

Dimensions in << mm >>
Dimensions and Tolerances for Proof Barrels
see Appendix CR 1.

Notes: 1) Check for safety reasons
* Basic dimensions