

C.I.P.

300 Blaser Mag.

Country of Origin: SE

TAB. I

Date 09-05-05

Revision

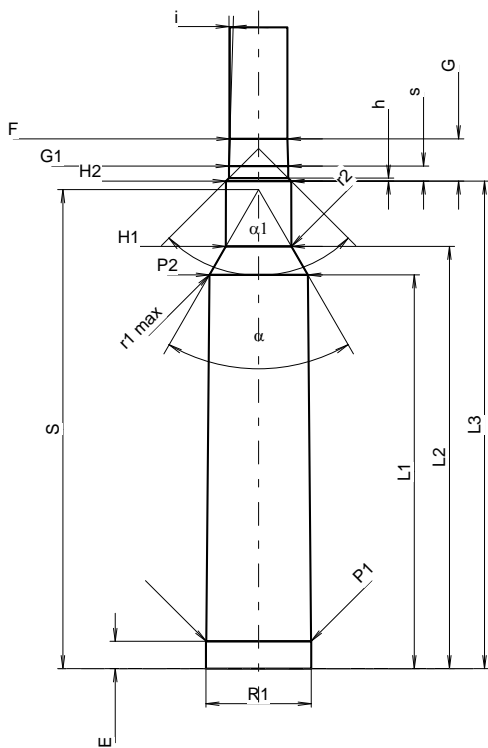
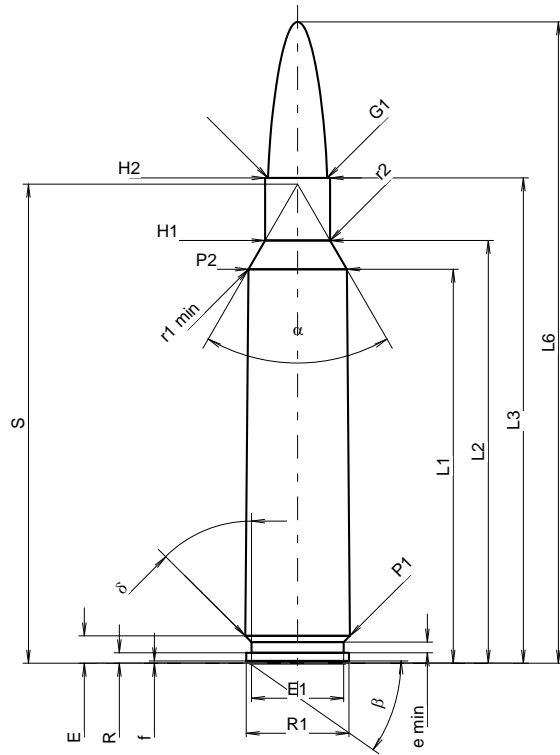

Scale 1:1

Dimensions in << mm >>
Dimensions and Tolerances for Proof Barrels
see Appendix CR 1.

CARTRIDGE MAXI

Lengths

L1 ¹⁾	=	52.12	-0.20
L2 ¹⁾	=	55.92	-0.20
L3 ¹⁾	=	64.20	
L4	=		
L5	=		
L6	=	84.84	

Case Head

R	=	1.37	
R1	=	13.59	
R3	=		
E	=	3.61	
E1	=	12.19	
e min	=	1.42	
delta	=	45°	
f	=	0.30	
beta	=	35°	

Powder Chamber

P1	=	13.84	
P2 ¹⁾ *	=	13.00	-0.20

Junction Cone

alpha *	=	60°	
S *	=	63.38	
r1 min	=	1.50	
r2	=	2.00	

Collar

H1 *	=	8.61	
H2 ¹⁾	=	8.61	

Projectile

G1 ¹⁾	=	7.83	
G2	=		
F	=		
L3+G ¹⁾	=	69.80	

Pressures (Energies)

Method Transducer

Pmax	=	4200 bar	
PK	=	4830 bar	
PE	=	5250 bar	
M	=	25.00	
EE	=	5545 Joule	

Miscellaneous Dimensions

Fe ¹⁾³⁾	=	0.10	
delta L	=		

CHAMBER MINI

Lengths

L1	=	52.10	
L2	=	55.87	
L3 ¹⁾	=	64.50	

Breech

R	=	1.37	
R1	=	13.92	
R2	=		
R3	=		
r	=		

Powder Chamber

E	=	3.61	
P1 ¹⁾	=	13.87	
P2 *	=	13.03	

Junction Cone

alpha ¹⁾ *	=	60°	
S *	=	63.38	
r1 max	=	1.50	
r2	=	2.00	

Collar

H1 *	=	8.68	
H2 ¹⁾	=	8.63	

Commencement of Rifling

G1 ¹⁾ *	=	7.84	
G ¹⁾	=	5.60	
alpha l	=	90°	
h	=	0.40	
s *	=	2.00	
i ¹⁾ *	=	1°45'	
w	=		

Barrel

F ¹⁾ *	=	7.62	
Z ¹⁾	=	7.82	

Grooves

b	=	4.49	
N	=	4	
u	=	279.40	
Q	=	47.52	mm ²

Notes: 1) Check for safety reasons
3) Headspace on Shoulder
* Basic dimensions