

C.I.P.**300 CR**

TAB.

I

Date

06-05-16

Revision

08-04-15

Country of Origin: BE

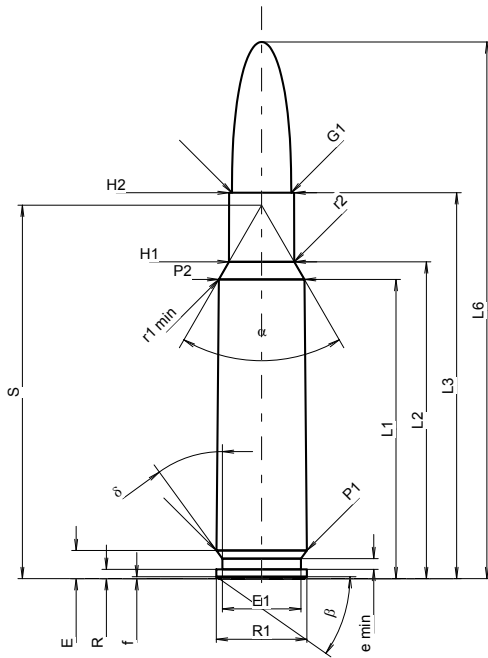
**CARTRIDGE MAXI****Lengths**

L1 ¹⁾	=	39.59	-0.20
L2 ¹⁾	=	41.92	-0.20
L3 ¹⁾	=	51.06	
L4	=		
L5	=		
L6	=	71.00	

Case Head

R	=	1.24	
R1	=	12.01	
R3	=		
E	=	3.72	
E1	=	10.39	
e min	=	1.40	
delta	=	36°	
f	=	0.26	
beta	=	35°	

Powder Chamber

P1	=	11.96	
P2 ¹⁾ *	=	11.34	-0.20

Junction Cone

alpha *	=	60°	
S *	=	49.41	
r1 min	=	0.74	
r2	=	3.18	

Collar

H1 *	=	8.65	
H2 ¹⁾	=	8.61	

Projectile

G1 ¹⁾	=	7.85	
G2	=		
F	=		
L3+G ¹⁾	=	59.64	

Pressures (Energies)**Method Transducer**

Pmax	=	4300 bar	
PK	=	4945 bar	
PE	=	5375 bar	
M	=	25.00	
EE	=	3675 Joule	

Miscellaneous Dimensions

Fe ¹⁾³⁾	=	0.10	
delta L	=		

CHAMBER MINI**Lengths**

L1	=	39.57	
L2	=	41.88	
L3 ¹⁾	=	51.32	

Breech

R	=		
R1	=	12.03	
R2	=		
R3	=		
r	=		

Powder Chamber

E	=	3.72	
P1 ¹⁾	=	12.00	
P2 *	=	11.36	

Junction Cone

alpha ¹⁾ *	=	60°	
S *	=	49.41	
r1 max	=	0.76	
r2	=	3.18	

Collar

H1 *	=	8.69	
H2 ¹⁾	=	8.64	

Commencement of Rifling

G1 ¹⁾ *	=	7.85	
G ¹⁾	=	8.58	
alpha1 *	=	90°	
h	=	0.39	
s	=	4.85	
i ¹⁾ *	=	1°45'	
w	=		

Barrel

F ¹⁾ *	=	7.62	
Z ¹⁾	=	7.82	

Grooves

b	=	2.41	
N	=	6	
u	=	305.00	
Q	=	47.07	mm ²

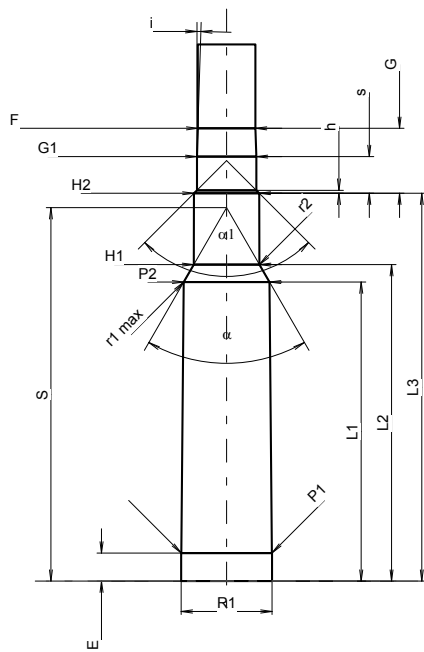

Scale 1:1

Dimensions in << mm >>
Dimensions and Tolerances for Proof Barrels
see Appendix CR 1.

Notes: 1) Check for safety reasons
3) Headspace on Shoulder
* Basic dimensions