

C.I.P.

300 Rem. Ultra Mag.

Country of Origin: US

TAB. I

Date 98-11-03

Revision 08-09-23

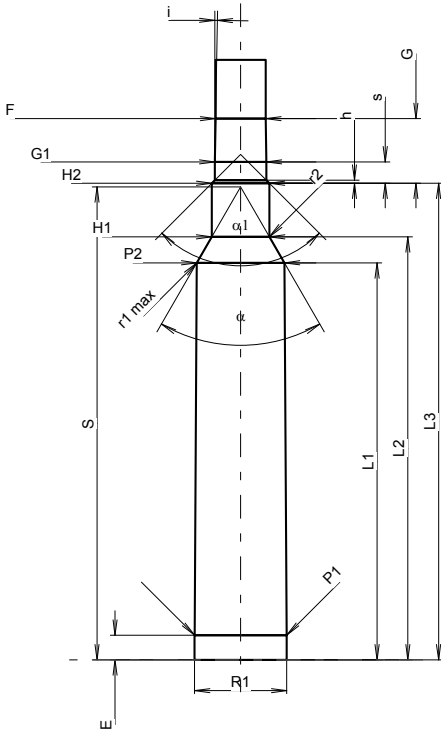
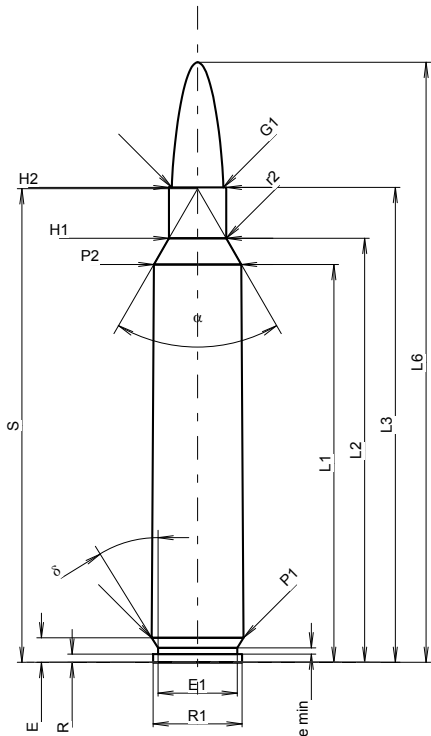

Scale 1:1.15

Dimensions in << mm >>
Dimensions and Tolerances for Proof Barrels
see Appendix CR 1.

CARTRIDGE MAXI

Lengths

L1 ¹⁾	=	60.64	-0.20
L2 ¹⁾	=	64.62	-0.20
L3 ¹⁾	=	72.39	
L4	=		
L5	=		
L6	=	91.44	

Case Head

R	=	1.27	
R1	=	13.56	
R3	=		
E	=	3.75	
E1	=	12.07	
e min	=	0.94	
delta	=	32°	
f	=		
beta	=	35°	

Powder Chamber

P1	=	13.97	
P2 ¹⁾ *	=	13.34	-0.20

Junction Cone

alpha *	=	60°	
S *	=	72.19	
r1 min	=		
r2	=	3.17	

Collar

H1 *	=	8.74	
H2 ¹⁾	=	8.74	

Projectile

G1 ¹⁾	=	7.85	
G2	=		
F	=		
L3+G ¹⁾	=	82.23	

Pressures (Energies)

Method Transducer

Pmax	=	4400 bar	
PK	=	5060 bar	
PE	=	5500 bar	
M	=	25.00	
EE	=	5985 Joule	

Miscellaneous Dimensions

Fe ¹⁾³⁾	=	0.10	
delta L	=	0.11	

CHAMBER MINI

Lengths

L1	=	60.51	
L2	=	64.47	
L3 ¹⁾	=	72.64	

Breech

R	=		
R1	=	14.05	
R2	=		
R3	=		
r	=		

Powder Chamber

E	=	3.75	
P1 ¹⁾	=	14.02	
P2 *	=	13.36	

Junction Cone

alpha ¹⁾ *	=	60°	
S *	=	72.08	
r1 max	=	0.78	
r2	=	3.18	

Collar

H1 *	=	8.79	
H2 ¹⁾	=	8.76	

Commencement of Rifling

G1 ¹⁾ *	=	7.85	
G ¹⁾	=	9.84	
alpha1 *	=	90°	
h	=	0.46	
s	=	3.25	
i ¹⁾ *	=	1°	
w	=		

Barrel

F ¹⁾ *	=	7.62	
Z ¹⁾	=	7.82	

Grooves

b	=	2.92	
N	=	6	
u	=	254.00	
Q	=	47.40	mm ²

Notes: 1) Check for safety reasons
3) Headspace on Shoulder
* Basic dimensions