

# C.I.P.

## 35 Whelen

Pays d'origine: US

TAB. I

Date 94-03-01

Révision 02-05-15

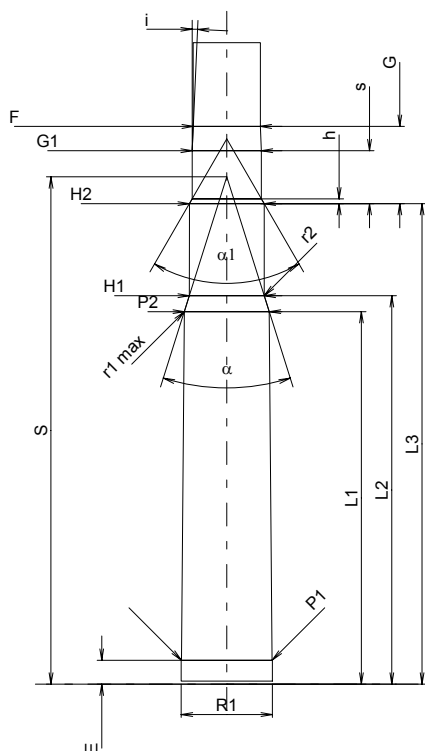
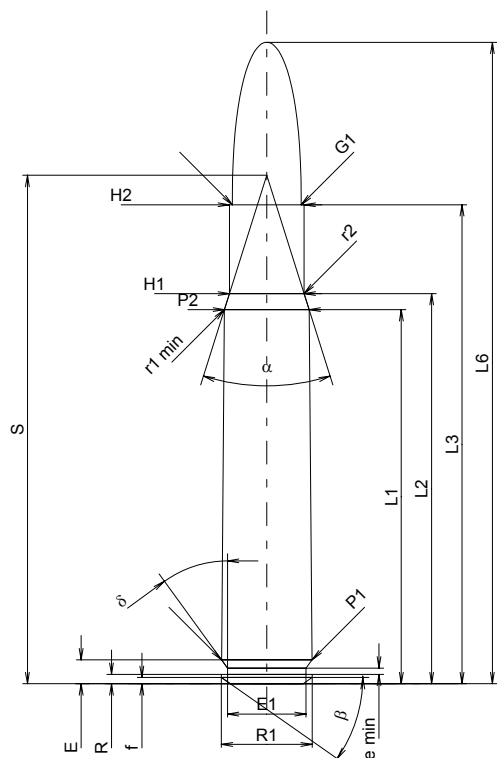

Échelle 1:1

Dimensions en << mm >>  
Dimensions et tolérances pour les canons  
d'épreuve: Voyez Annexe CR 1.

### CARTOUCHE MAXI

#### Longueurs

L1 <sup>1)</sup>	=	49.48	-0.20
L2 <sup>1)</sup>	=	51.60	-0.20
L3 <sup>1)</sup>	=	63.35	
L4	=		
L5	=		
L6	=	84.84	

#### Culot

R	=	1.24	
R1	=	12.01	
R3	=		
E	=	3.16	
E1	=	10.39	
e min	=	0.84	
delta	=	36°	
f	=	0.83	
beta	=	35°	

#### Chambre à poudre

P1	=	11.96	
P2 <sup>1)*</sup>	=	11.20	-0.20

#### Cône de raccordement

alpha*	=	35°	
S*	=	67.24	
r1 min	=	1.27	
r2	=	2.54	

#### Collet

H1*	=	9.86	
H2 <sup>1)</sup>	=	9.86	

#### Projectile

G1 <sup>1)</sup>	=	9.12	
G2	=		
F	=		
L3+G <sup>1)</sup>	=	73.56	

#### Pressions (Énergies)

##### Méthode transducteur

Pmax	=	4000 bar	
PK	=	4600 bar	
PE	=	5000 bar	
M	=	25.00	
EE	=	4560 Joule	

#### Autres indications

Fe <sup>1)</sup>	=	0.10	
delta L	=		

### CHAMBRE MINI

#### Longueurs

L1	=	49.27	
L2	=	51.37	
L3 <sup>1)</sup>	=	63.55	

#### Cuvette

R	=		
R1	=	12.04	
R2	=		
R3	=		
r	=		

#### Chambre à poudre

E	=	3.16	
P1 <sup>1)</sup>	=	11.99	
P2*	=	11.24	

#### Cône de raccordement

alpha <sup>1)*</sup>	=	35°	
S*	=	67.09	
r1 max	=	1.27	
r2	=	2.54	

#### Collet

H1*	=	9.91	
H2 <sup>1)</sup>	=	9.88	

#### Prise de rayures

G1 <sup>1)*</sup>	=	9.14	
G <sup>1)</sup>	=	10.21	
alpha1*	=	60°	
h	=	0.64	
s	=	7.00	
i <sup>1)*</sup>	=	2°30'	
w	=		

#### Canon

F <sup>1)*</sup>	=	8.86	
Z <sup>1)</sup>	=	9.07	

#### Rayures

b	=	3.30	
N	=	6	
u	=	406.40	
Q	=	63.78	mm <sup>2</sup>

Notes: 1) A' contrôler pour la sécurité  
\* Dimensions de base