

**C.I.P.****5,6 x 39**

TAB.

I

Date

00-02-15

Révision

07-05-14

Pays d'origine: RU

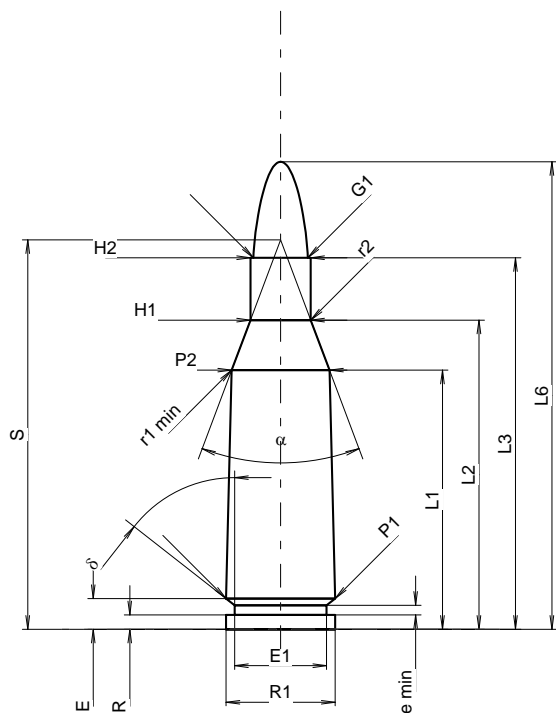
**CARTOUCHE MAXI****Longueurs**

L1 <sup>1)*</sup>	=	27.00	-0.20
L2 <sup>1)*</sup>	=	32.20	-0.20
L3 <sup>1)</sup>	=	38.70	
L4	=		
L5	=		
L6	=	48.70	

**Culot**

R	=	1.50	
R1	=	11.35	
R3	=		
E	=	3.20	
E1	=	9.56	
e min	=	1.00	
delta	=	51°58'13"	
f	=		
beta	=		

**Chambre à poudre**

P1	=	11.35	
P2 <sup>1)*</sup>	=	10.20	-0.20

**Cône de raccordement**

alpha	=	41°12'31"	
S	=	40.57	
r1 min	=	0.50	
r2	=	2.00	

**Collet**

H1 *	=	6.29	
H2 <sup>1)</sup>	=	6.29	

**Projectile**

G1 <sup>1)</sup>	=	5.67	
G2	=		
F	=		
L3+G <sup>1)</sup>	=	49.01	

**Pressions (Énergies)****Méthode transducteur**

Pmax	=	3500 bar	
PK	=	4025 bar	
PE	=	4375 bar	
M	=	17.50	
EE	=	2100 Joule	

**Autres indications**

Fe <sup>1)3)</sup>	=	0.15	
delta L	=	0.06	

**CHAMBRE MINI****Longueurs**

L1 *	=	26.88	
L2 *	=	32.22	
L3 <sup>1)</sup>	=	38.70	

**Cuvette**

R	=	1.50	
R1	=	11.40	
R2	=		
R3	=		
r	=		

**Chambre à poudre**

E	=	3.50	
P1 <sup>1)</sup>	=	11.34	
P2 *	=	10.24	

**Cône de raccordement**

alpha <sup>1)</sup>	=	39°38'50"	
S	=	41.08	
r1 max	=	0.50	
r2	=	2.50	

**Collet**

H1 *	=	6.39	
H2 <sup>1)</sup>	=	6.29	

**Prise de rayures**

G1 <sup>1)*</sup>	=	5.78	
G <sup>1)*</sup>	=	10.31	
alpha l	=	23°59'38"	
h	=	1.20	
s *	=	6.00	
i <sup>1)</sup>	=	2°11'33"	
w	=		

**Canon**

F <sup>1)*</sup>	=	5.45	
Z <sup>1)</sup>	=	5.59	

**Rayures**

b	=	2.00	
N	=	6	
u	=	420.00	
Q	=	24.19	mm <sup>2</sup>

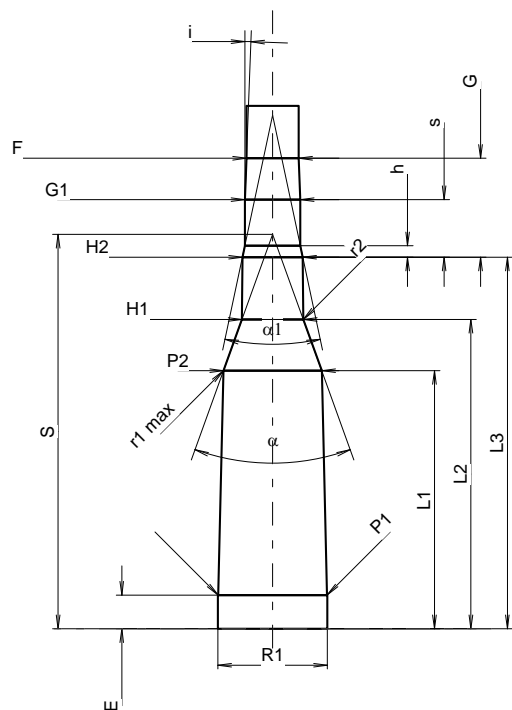

Échelle 1.27:1

Dimensions en << mm >>  
Dimensions et tolérances pour les canons  
d'épreuve: Voyez Annexe CR 1.

Notes: 1) A' contrôler pour la sécurité  
3) Feuillure sur la cone de raccordement  
\* Dimensions de base