

C.I.P.**10,3 x 60 R**

TAB.

II

Date

84-06-14

Revision

25-05-13

Country of Origin: CH

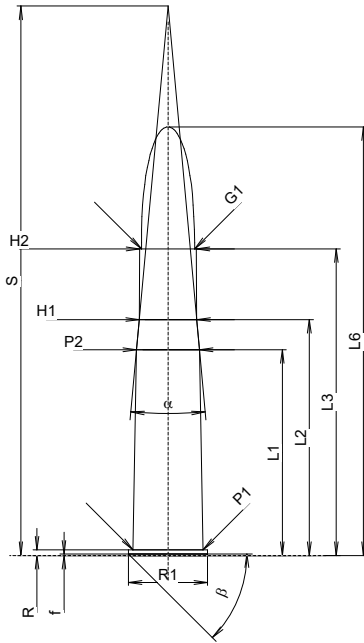
**CARTRIDGE MAXI****Lengths**

L1	=	40.80
L2	=	46.80
L3 ¹⁾	=	60.80
L4	=	
L5	=	
L6	=	85.00

Case Head

R ¹⁾	=	1.10	-0.25
R1	=	15.70	
R3	=		
E	=		
E1	=		
e min	=		
delta	=	0°	
f	=	0.30	
beta	=	45°	

Powder Chamber

P1	=	13.85
P2 *	=	12.50

Junction Cone

alpha *	=	10°28'30"
S *	=	108.98
r1 min	=	
r2	=	

Collar

H1 *	=	11.40
H2 ¹⁾	=	11.26

Projectile

G1 ¹⁾	=	10.54
G2	=	
F	=	
L3+G ¹⁾	=	77.30

Pressures (Energies)**Method Transducer**

Pmax	=	2700 bar
PK	=	3105 bar
PE	=	3375 bar
M	=	25.00
EE	=	4620 Joule

Miscellaneous Dimensions

Fe ¹⁾	=	0.15
delta L	=	

CHAMBER MINI**Lengths**

L1	=	41.50
L2	=	47.40
L3 ¹⁾	=	61.90

Breech

R ¹⁾	=	1.20
R1	=	16.10
R2	=	
R3	=	
r	=	

Powder Chamber

E	=	
P1 ¹⁾	=	13.95
P2 *	=	12.55

Junction Cone

alpha *	=	11°07'59"
S *	=	105.88
r1 max	=	
r2	=	

Collar

H1 *	=	11.40
H2 ¹⁾	=	11.35

Commencement of Rifling

G1 ¹⁾ *	=	10.65
G ¹⁾	=	16.50
alpha1 *	=	90°
h	=	0.35
s	=	0.50
i ¹⁾ *	=	0°42'57"
w	=	

Barrel

F ¹⁾ *	=	10.25
Z ¹⁾	=	10.49

Grooves

b	=	3.60
N	=	6
u	=	450.00
Q	=	85.16 mm ²

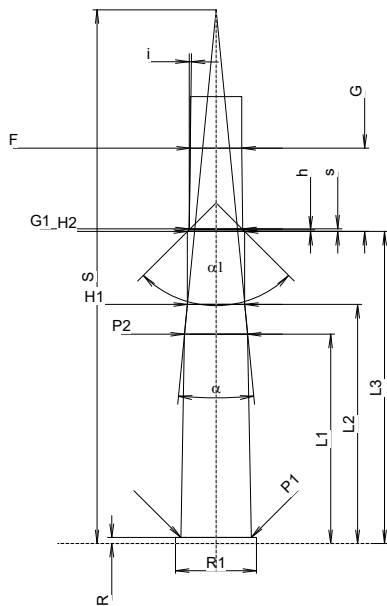

Scale 1:1.5

Dimensions in << mm >>
Dimensions and Tolerances for Proof Barrels
see Appendix CR 1.

Notes: 1) Check for safety reasons
* Basic dimensions