

C.I.P.**10,3 x 60 R**

TAB.

II

Date

84-06-14

Pays d'origine: CH

Révision

25-05-13

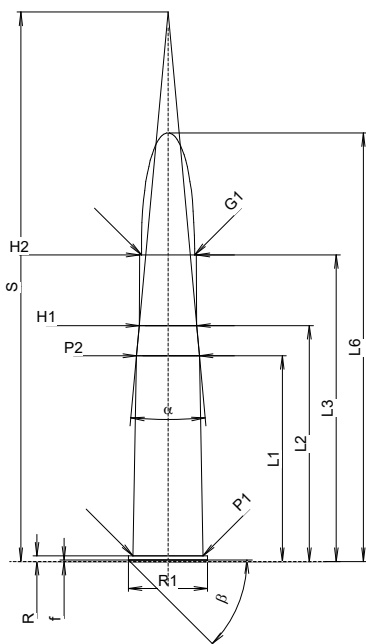
**CARTOUCHE MAXI****Longueurs**

| | | |
|------------------|---|-------|
| L1 | = | 40.80 |
| L2 | = | 46.80 |
| L3 ¹⁾ | = | 60.80 |
| L4 | = | |
| L5 | = | |
| L6 | = | 85.00 |

Colot

| | | | |
|-----------------|---|-------|-------|
| R ¹⁾ | = | 1.10 | -0.25 |
| R1 | = | 15.70 | |
| R3 | = | | |
| E | = | | |
| E1 | = | | |
| e min | = | | |
| delta | = | 0° | |
| f | = | 0.30 | |
| beta | = | 45° | |

Chambre à poudre

| | | |
|------|---|-------|
| P1 | = | 13.85 |
| P2 * | = | 12.50 |

Cône de raccordement

| | | |
|---------|---|-----------|
| alpha * | = | 10°28'30" |
| S * | = | 108.98 |
| r1 min | = | |
| r2 | = | |

Collet

| | | |
|------------------|---|-------|
| H1 * | = | 11.40 |
| H2 ¹⁾ | = | 11.26 |

Projectile

| | | |
|--------------------|---|-------|
| G1 ¹⁾ | = | 10.54 |
| G2 | = | |
| F | = | |
| L3+G ¹⁾ | = | 77.30 |

Pressions (Énergies)**Méthode transducteur**

| | | |
|------|---|------------|
| Pmax | = | 2700 bar |
| PK | = | 3105 bar |
| PE | = | 3375 bar |
| M | = | 25.00 |
| EE | = | 4620 Joule |

Autres indications

| | | |
|------------------|---|------|
| Fe ¹⁾ | = | 0.15 |
| delta L | = | |

CHAMBRE MINI**Longueurs**

| | | |
|------------------|---|-------|
| L1 | = | 41.50 |
| L2 | = | 47.40 |
| L3 ¹⁾ | = | 61.90 |

Cuvette

| | | |
|-----------------|---|-------|
| R ¹⁾ | = | 1.20 |
| R1 | = | 16.10 |
| R2 | = | |
| R3 | = | |
| r | = | |

Chambre à poudre

| | | |
|------------------|---|-------|
| E | = | |
| P1 ¹⁾ | = | 13.95 |
| P2 * | = | 12.55 |

Cône de raccordement

| | | |
|---------|---|-----------|
| alpha * | = | 11°07'59" |
| S * | = | 105.88 |
| r1 max | = | |
| r2 | = | |

Collet

| | | |
|------------------|---|-------|
| H1 * | = | 11.40 |
| H2 ¹⁾ | = | 11.35 |

Prise de rayures

| | | |
|--------------------|---|----------|
| G1 ¹⁾ * | = | 10.65 |
| G ¹⁾ | = | 16.50 |
| alpha1 * | = | 90° |
| h | = | 0.35 |
| s | = | 0.50 |
| i ¹⁾ * | = | 0°42'57" |
| w | = | |

Canon

| | | |
|-------------------|---|-------|
| F ¹⁾ * | = | 10.25 |
| Z ¹⁾ | = | 10.49 |

Rayures

| | | |
|---|---|-----------------------|
| b | = | 3.60 |
| N | = | 6 |
| u | = | 450.00 |
| Q | = | 85.16 mm ² |

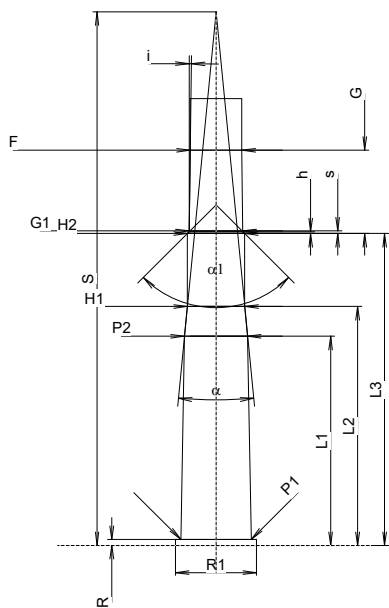

Échelle 1:1.5

Dimensions en << mm >>
Dimensions et tolérances pour les canons
d'épreuve: Voyez Annexe CR 1.

Notes: 1) A' contrôler pour la sécurité
* Dimensions de base