

**C.I.P.****7,62 x 54 R**

TAB.

II

Date

84-06-14

Révision

14-05-20

Pays d'origine: SU

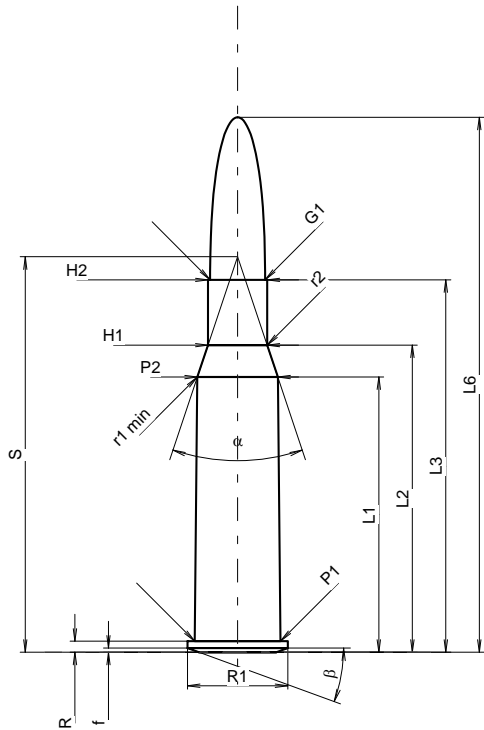
**CARTOUCHE MAXI****Longueurs**

L1 *	=	39.70
L2 *	=	44.30
L3 <sup>1)</sup>	=	53.72
L4	=	
L5	=	57.00
L6	=	77.16

**Culot**

R <sup>1)</sup>	=	1.60	-0.25
R1	=	14.48	
R3	=		
E	=		
E1	=		
e min	=		
delta	=		
f	=	0.60	
beta	=	20°	

**Chambre à poudre**

P1	=	12.37
P2 *	=	11.61

**Cône de raccordement**

alpha	=	37°01'9"
S	=	57.04
r1 min	=	0.50
r2	=	0.50

**Collet**

H1 *	=	8.53
H2 <sup>1)</sup>	=	8.53

**Projectile**

G1 <sup>1)</sup>	=	7.92
G2	=	
F	=	
L3+G <sup>1)</sup>	=	74.80

**Pressions (Énergies)****Méthode transducteur**

Pmax	=	3900 bar
PK	=	4485 bar
PE	=	4875 bar
M	=	25.00
EE	=	3960 Joule

**Autres indications**

Fe <sup>1)4)</sup>	=	0.10
delta L	=	

**CHAMBRE MINI****Longueurs**

L1 *	=	39.73
L2 *	=	44.30
L3 <sup>1)</sup>	=	53.70

**Cuvette**

R <sup>1)</sup>	=	1.63
R1	=	14.50
R2	=	
R3	=	
r	=	

**Chambre à poudre**

E	=	
P1 <sup>1)</sup>	=	12.48
P2 *	=	11.68

**Cône de raccordement**

alpha <sup>1)</sup>	=	37°07'59"
S	=	57.12
r1 max	=	0.50
r2	=	0.50

**Collet**

H1 *	=	8.61
H2 <sup>1)</sup>	=	8.60

**Prise de rayures**

G1 <sup>1)</sup> *	=	7.93
G <sup>1)</sup> *	=	21.08
alpha 1	=	12°31'48"
h *	=	3.05
s	=	
i <sup>1)</sup> *	=	0°29'33"
w	=	

**Canon**

F <sup>1)</sup> *	=	7.62
Z <sup>1)</sup>	=	7.92

**Rayures**

b	=	3.81
N	=	4
u	=	240.00
Q	=	47.99 mm <sup>2</sup>

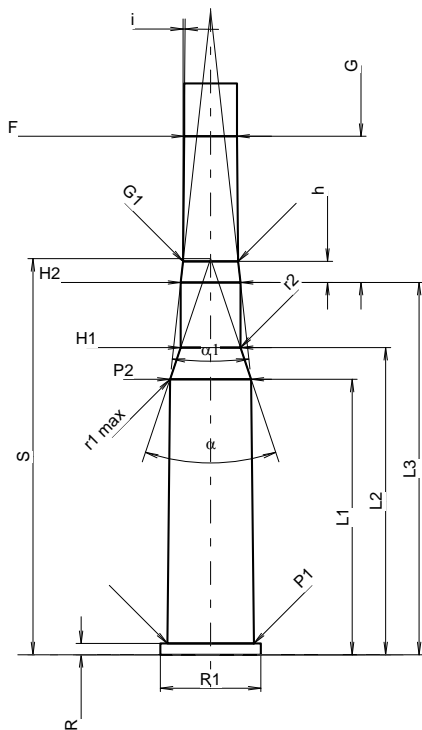

Échelle 1:1.09

Dimensions en << mm >>  
Dimensions et tolérances pour les canons  
d'épreuve: Voyez Annexe CR 1.

Notes: 1) A' contrôler pour la sécurité  
4) Feuillure sur la bourrelet  
\* Dimensions de base