

C.I.P.**6 x 52 R Bretschneider**

TAB. II

Datum 98-01-27

Revision 02-05-15

Ursprungsland: DE

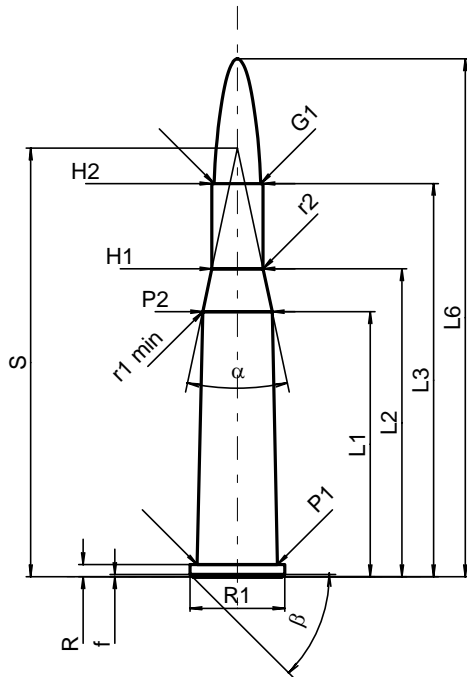
**PATRONE MAXI****Längen**

L1*	=	35.04
L2*	=	40.73
L3 ¹⁾	=	52.00
L4	=	
L5	=	
L6	=	68.50

Hülsenboden

R ¹⁾	=	1.60	-0.25
R1	=	12.50	
R3	=		
E	=		
E1	=		
e min	=		
delta	=		
f	=	0.30	
beta	=	45°	

Pulverkammer

P1	=	10.62
P2*	=	9.20

Schulterkonus

alpha	=	24°00'38"
S	=	56.67
r1 min	=	0.50
r2	=	0.50

Hülsenhals

H1*	=	6.78
H2 ¹⁾	=	6.78

Geschoss

G1 ¹⁾	=	6.17
G2	=	
F	=	
L3+G ¹⁾	=	58.67

Drücke (Energien)**Mech. elektr. Wandler**

Pmax	=	3300 bar
PK	=	3795 bar
PE	=	4125 bar
M	=	25.00
EE	=	2205 Joule

Verschiedene Daten

Fe ¹⁾	=	0.15
delta L	=	

PATRONENLAGER MINI**Längen**

L1*	=	35.03
L2*	=	40.72
L3 ¹⁾	=	52.30

Stoßboden

R ¹⁾	=	1.60
R1	=	12.55
R2	=	
R3	=	
r	=	

Pulverkammer

E	=	
P1 ¹⁾	=	10.65
P2*	=	9.23

Schulterkonus

alpha	=	24°00'38"
S	=	56.73
r1 max	=	3.80
r2	=	7.50

Hülsenhals

H1*	=	6.81
H2 ¹⁾	=	6.80

Geschossübergang

G1 ¹⁾ *	=	6.19
G ¹⁾ *	=	6.67
alpha1	=	90°
h	=	0.31
s*	=	3.00
i ¹⁾	=	1°19'36"
w	=	

Lauf

F ¹⁾ *	=	6.02
Z ¹⁾	=	6.17

Züge

b	=	1.73
N	=	6
u	=	254.00
Q	=	29.25 mm ²

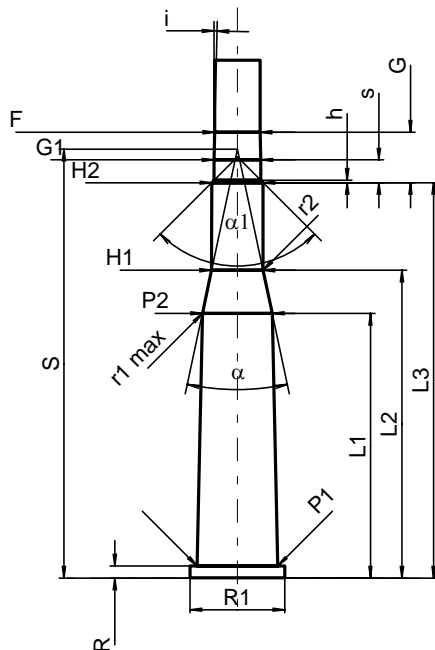

Maßstab 1:1

Maße in << mm >>
Maße und Toleranzen für Messläufe
siehe Anhang CR 1.

Bemerkungen: 1) Kontrolle aus Sicherheitsgründen
* Grundmaße