

# C.I.P.

## 6,5 x 51 R (Arisaka)

Country of Origin: JP

TAB. II

Date 84-06-14

Revision 08-09-23

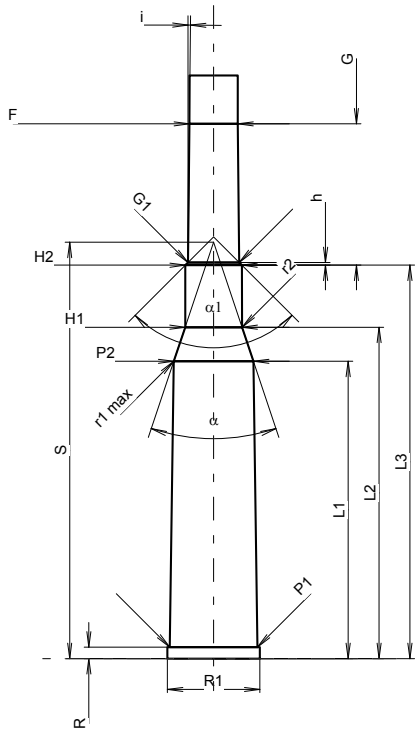
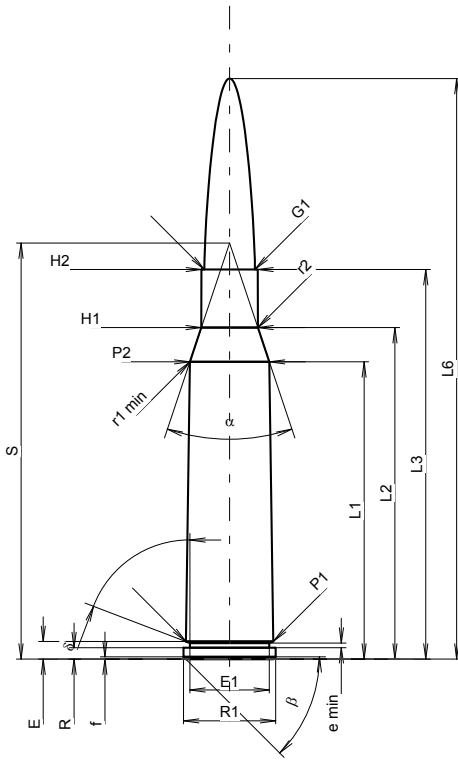

Scale 1.01:1

Dimensions in << mm >>  
Dimensions and Tolerances for Proof Barrels  
see Appendix CR 1.

### CARTRIDGE MAXI

#### Lengths

L1	=	38.92
L2	=	43.40
L3 <sup>1)</sup>	=	51.00
L4	=	
L5	=	
L6	=	76.00

#### Case Head

R <sup>1)</sup>	=	1.50	-0.25
R1	=	12.08	
R3	=		
E	=	2.30	
E1	=	10.40	
e min	=	0.60	
delta	=	60°	
f	=	0.30	
beta	=	45°	

#### Powder Chamber

P1	=	11.45
P2 *	=	10.40

#### Junction Cone

alpha *	=	37°
S *	=	54.46
r1 min	=	0.50
r2	=	0.50

#### Collar

H1 *	=	7.40
H2 <sup>1)</sup>	=	7.37

#### Projectile

G1 <sup>1)</sup>	=	6.63
G2	=	
F	=	
L3+G <sup>1)</sup>	=	69.50

#### Pressures (Energies)

##### Method Transducer

Pmax	=	2950 bar
PK	=	3393 bar
PE	=	3688 bar
M	=	25.00
EE	=	2625 Joule

#### Miscellaneous Dimensions

Fe <sup>1)3)</sup>	=	0.15
delta L	=	

### CHAMBER MINI

#### Lengths

L1	=	38.92
L2	=	43.38
L3 <sup>1)</sup>	=	51.50

#### Breech

R <sup>1)</sup>	=	1.50
R1	=	12.12
R2	=	
R3	=	
r	=	

#### Powder Chamber

E	=	
P1 <sup>1)</sup>	=	11.48
P2 *	=	10.43

#### Junction Cone

alpha *	=	37°
S *	=	54.51
r1 max	=	0.50
r2	=	0.50

#### Collar

H1 *	=	7.45
H2 <sup>1)</sup>	=	7.40

#### Commencement of Rifling

G1 <sup>1)</sup> *	=	6.69
G <sup>1)</sup>	=	18.50
alpha1 *	=	90°
h	=	0.35
s	=	
i <sup>1)</sup> *	=	0°34'05"
w	=	

#### Barrel

F <sup>1)</sup> *	=	6.33
Z <sup>1)</sup>	=	6.63

#### Grooves

b	=	3.50
N	=	4
u	=	200.00
Q	=	33.69 mm <sup>2</sup>

Notes: 1) Check for safety reasons  
3) Headspace on Shoulder  
\* Basic dimensions