

C.I.P.**6,5 x 68 R**

TAB. II

Date 84-06-14

Country of Origin: DE

Revision 02-05-15

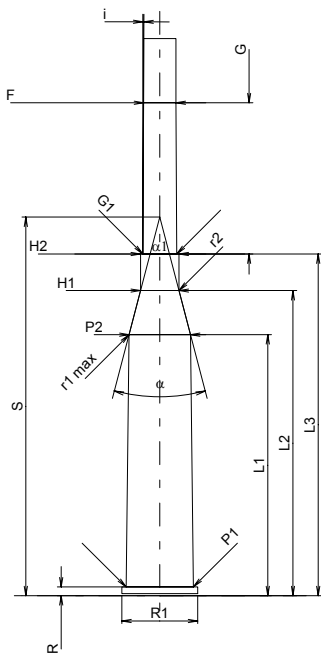
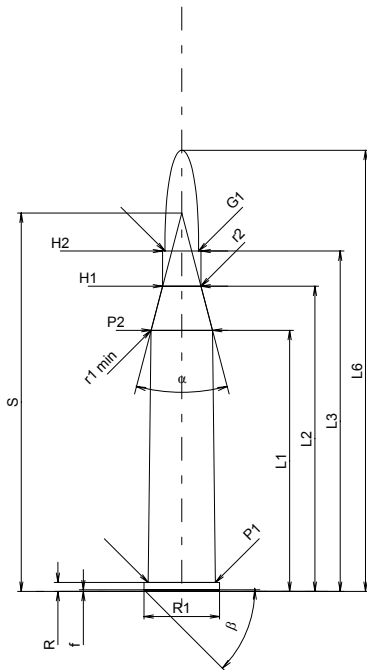

Scale 1:1.5

Dimensions in << mm >>
Dimensions and Tolerances for Proof Barrels
see Appendix CR 1.

CARTRIDGE MAXI**Lengths**

L1 *	=	51.78
L2 *	=	60.53
L3 ¹⁾	=	67.50
L4	=	
L5	=	
L6	=	87.50

Case Head

R ¹⁾	=	1.75	-0.25
R1	=	15.00	
R3	=		
E	=		
E1	=		
e min	=		
delta	=		
f	=	0.30	
beta	=	45°	

Powder Chamber

P1	=	13.34
P2 *	=	12.18

Junction Cone

alpha	=	29°19'59"
S	=	75.05
r1 min	=	0.50
r2	=	0.50

Collar

H1 *	=	7.60
H2 ¹⁾	=	7.60

Projectile

G1 ¹⁾	=	6.70
G2	=	
F	=	
L3+G ¹⁾	=	97.50

Pressures (Energies)**Method Transducer**

Pmax	=	3900 bar
PK	=	4485 bar
PE	=	4875 bar
M	=	25.00
EE	=	3810 Joule

Miscellaneous Dimensions

Fe ¹⁾	=	0.10
delta L	=	

CHAMBER MINI**Lengths**

L1 *	=	51.78
L2 *	=	60.53
L3 ¹⁾	=	67.80

Breech

R ¹⁾	=	1.75
R1	=	15.05
R2	=	
R3	=	
r	=	

Powder Chamber

E	=	
P1 ¹⁾	=	13.37
P2 *	=	12.21

Junction Cone

alpha	=	29°19'58"
S	=	75.11
r1 max	=	0.50
r2	=	0.50

Collar

H1 *	=	7.63
H2 ¹⁾	=	7.63

Commencement of Rifling

G1 ¹⁾ *	=	6.75
G ¹⁾ *	=	30.00
alpha1	=	180°
h	=	
s	=	
i ¹⁾	=	0°17'11"
w	=	

Barrel

F ¹⁾ *	=	6.45
Z ¹⁾	=	6.70

Grooves

b	=	3.50
N	=	4
u	=	250.00
Q	=	34.52 mm ²

Notes: 1) Check for safety reasons
* Basic dimensions