

C.I.P.**9 x 53 R**

TAB. II

Date 99-03-23

Revision 07-05-14

Country of Origin: RU

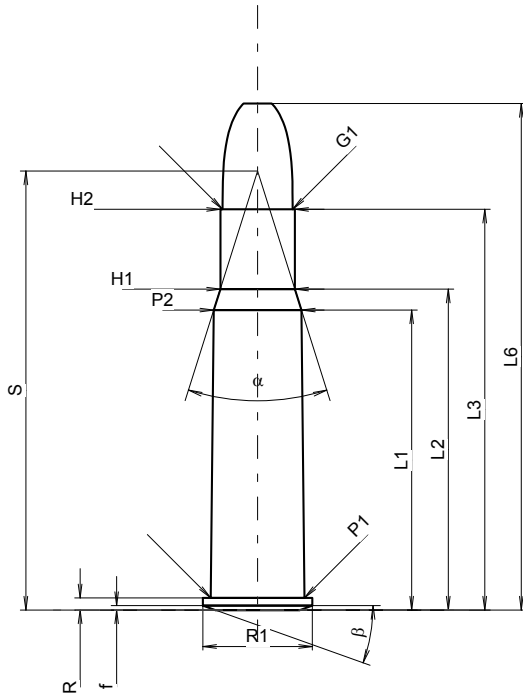
**CARTRIDGE MAXI****Lengths**

L1 *	=	39.68
L2 *	=	42.45
L3 ¹⁾	=	53.00
L4	=	
L5	=	
L6	=	67.00

Case Head

R	=	1.60	
R1	=	14.48	-0.25
R3	=		
E	=		
E1	=		
e min	=		
delta	=		
f	=	0.58	
beta	=	19°40'	

Powder Chamber

P1	=	12.42
P2 *	=	11.61

Junction Cone

alpha	=	35°03'40"
S	=	58.06
r1 min	=	
r2	=	

Collar

H1 *	=	9.86
H2 ¹⁾	=	9.86

Projectile

G1 ¹⁾	=	9.27
G2	=	
F	=	
L3+G ¹⁾	=	60.70

Pressures (Energies)**Method Transducer**

Pmax	=	3400 bar
PK	=	3910 bar
PE	=	4420 bar
M	=	25.00
EE	=	3800 Joule

Miscellaneous Dimensions

Fe ¹⁾⁴⁾	=	0.15
delta L	=	

CHAMBER MINI**Lengths**

L1 *	=	39.70
L2 *	=	42.50
L3 ¹⁾	=	53.30

Breech

R ¹⁾	=	1.60
R1	=	14.50
R2	=	
R3	=	
r	=	

Powder Chamber

E	=	
P1 ¹⁾	=	12.51
P2 *	=	11.68

Junction Cone

alpha ¹⁾	=	33°57'38"
S	=	56.83
r1 max	=	
r2	=	

Collar

H1 *	=	9.97
H2 ¹⁾	=	9.90

Commencement of Rifling

G1 ¹⁾ *	=	9.33
G ¹⁾ *	=	7.70
alpha 1	=	60°
h *	=	0.49
s *	=	6.20
i ¹⁾	=	6°16'38"
w	=	

Barrel

F ¹⁾ *	=	9.00
Z ¹⁾	=	9.25

Grooves

b	=	3.00
N	=	6
u	=	240.00
Q	=	65.91 mm ²

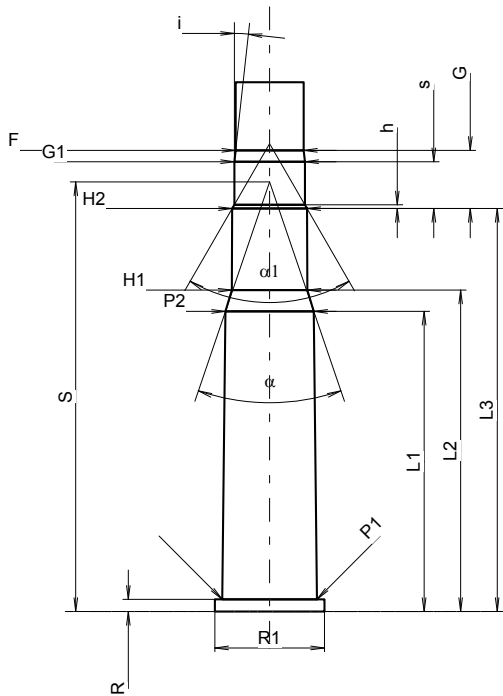

Scale 1:1

Dimensions in << mm >>
 Dimensions and Tolerances for Proof Barrels
 see Appendix CR 1.

Notes: 1) Check for safety reasons
 4) Headspace on Rim
 * Basic dimensions