

**C.I.P.****8 mm - 348 Win.**

TAB. II

Date 99-03-16

Pays d'origine: FR

Révision 02-05-15

**CARTOUCHE MAXI****CHAMBRE MINI****Longueurs**

L1 <sup>*</sup>	=	41.91
L2 <sup>*</sup>	=	46.88
L3 <sup>1)</sup>	=	57.28
L4	=	
L5	=	
L6	=	82.00

**Longueurs**

L1 <sup>*</sup>	=	42.17
L2 <sup>*</sup>	=	47.12
L3 <sup>1)</sup>	=	57.53

**Culot**

R <sup>1)</sup>	=	1.78	-0.25
R1	=	15.49	
R3	=		
E	=		
E1	=		
e min	=		
δ	=		
f	=	0.38	
β	=	35°	

**Cuvette**

R <sup>1)</sup>	=	1.78
R1	=	15.75
R2	=	
R3	=	
r	=	

**Chambre à poudre**

P1	=	14.05
P2 <sup>*</sup>	=	12.32

**Chambre à poudre**

E	=	
P1 <sup>1)</sup>	=	14.07
P2 <sup>*</sup>	=	12.34

**Cône de raccordement**

α	=	38°10'45"
S	=	59.71
r1 min	=	0.76
r2	=	2.54

**Cône de raccordement**

α	=	38°19'19"
S	=	59.93
r1 max	=	0.76
r2	=	2.54

**Collet**

H1 <sup>*</sup>	=	8.88
H2 <sup>1)</sup>	=	8.85

**Collet**

H1 <sup>*</sup>	=	8.90
H2 <sup>1)</sup>	=	8.87

**Projectile**

G1 <sup>1)</sup>	=	8.22
G2	=	
F	=	
L3+G <sup>1)</sup>	=	66.77

**Prise de rayures**

G1 <sup>1)</sup> *	=	8.23
G <sup>1)</sup> *	=	9.49
α1	=	90°
h	=	0.32
s <sup>*</sup>	=	3.00
i <sup>1)</sup>	=	1°30'02"
w	=	

**Pressions (Énergies)****Méthode transducteur**

Pmax	=	3000 bar
PK	=	3450 bar
PE	=	3750 bar
M	=	25.00
EE	=	2600 Joule

**Canon**

F <sup>1)</sup> *	=	7.89
Z <sup>1)</sup>	=	8.20

**Rayures**

b	=	4.05
N	=	4
u	=	240.00
Q	=	51.52 mm <sup>2</sup>

**Autres indications**

Fe <sup>1)</sup>	=	0.15
delta L	=	

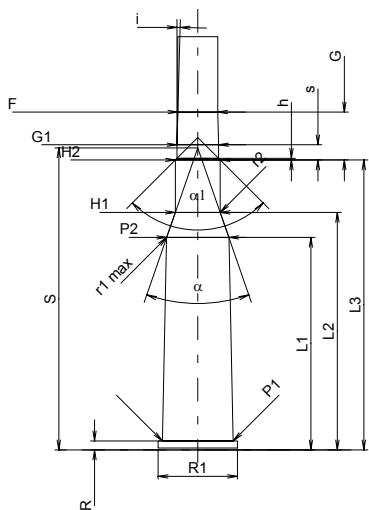
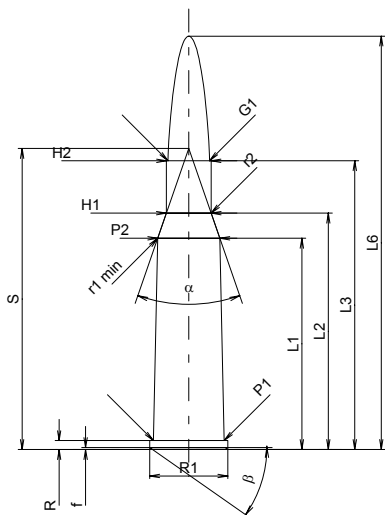

Échelle 1:1.5

Dimensions en << mm >>  
Dimensions et tolérances pour les canons  
d'épreuve: Voyez Annexe CR 1.

Notes: 1) A' contrôler pour la sécurité  
\* Dimensions de base