

C.I.P.**9 mm Browning court**

TAB. IV

Datum 84-06-14

Revision 08-09-23

Ursprungsland: BE

Alternative Namen: 9mm Browning Kurz (short, corto), 9 mm kurz, 380 ACP, 380 Auto(matic)

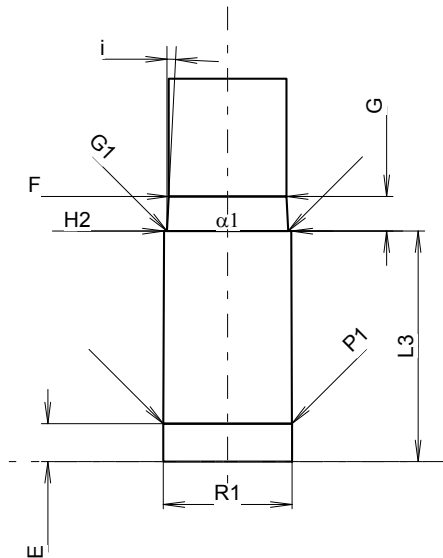
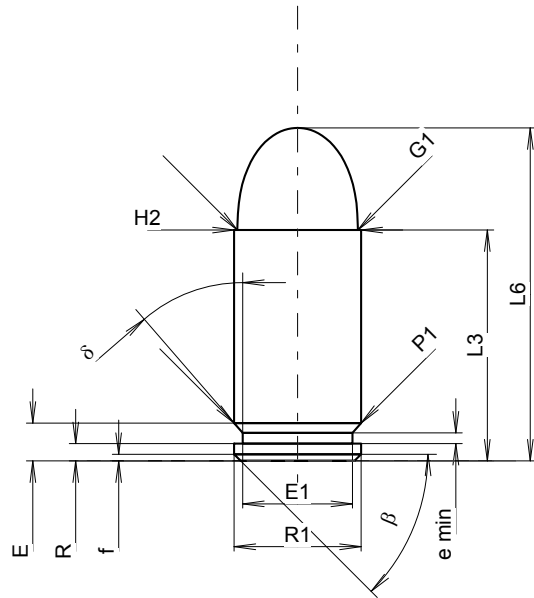

Maßstab 1.76:1

Maße in << mm >>
Maße und Toleranzen für Messläufe
siehe Anhang CR 1.

PATRONE MAXI**Längen**

L1	=		
L2	=		
L3 ¹⁾	=	17.33	-0.25
L4	=		
L5	=		
L6	=	25.00	

Hülsenboden

R	=	1.30	
R1	=	9.53	
R3	=		
E	=	2.84	
E1	=	8.25	
e min	=	0.80	
delta	=	40°	
f	=	0.50	
beta	=	45°	

Pulverkammer

P1	=	9.53	
P2	=		

Schulterkonus

alpha	=		
S	=		
r1 min	=		
r2	=		

Hülsenhals

H1	=		
H2 ¹⁾	=	9.53	

Geschoss

G1 ¹⁾	=	9.04	
G2	=		
F	=		
L3+G ¹⁾	=	19.93	

Drücke (Energien)**Mech. elektr. Wandler**

Pmax	=	1350 bar	
PK	=	1553 bar	
PE	=	1755 bar	
M	=	9.00	

Verschiedene Daten

Fe ¹⁾⁶⁾	=	0.30	
delta L	=		

PATRONENLAGER MINI**Längen**

L1	=		
L2	=		
L3 ¹⁾	=	17.30	

Stoßboden

R	=		
R1	=	9.66	
R2	=		
R3	=		
r	=		

Pulverkammer

E	=	2.84	
P1 ¹⁾	=	9.65	
P2	=		

Schulterkonus

alpha	=		
S	=		
r1 max	=		
r2	=		

Hülsenhals

H1	=		
H2 ¹⁾	=	9.55	

Geschossübergang

G1 ¹⁾ *	=	9.10	
G ¹⁾ *	=	2.60	
alpha1	=	180°	
h	=		
s	=		
i ¹⁾	=	2°51'45"	
w	=		

Lauf

F ¹⁾ *	=	8.84	
Z ¹⁾	=	9.04	

Züge

b	=	3.07	
N	=	6	
u	=	250.00	
Q	=	63.26	mm ²

Bemerkungen: 1) Kontrolle aus Sicherheitsgründen
6) Verschlussabstand an Hülsenmund
* Grundmaße