

C.I.P.**30-357 AeT**

TAB. IV

Datum 00-09-12

Revision 02-05-15

Ursprungsland: IT

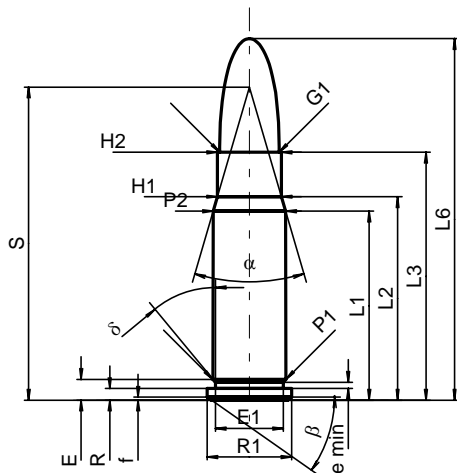
**PATRONE MAXI****Längen**

L1 ^{1)*}	=	24.98	-0.20
L2 ^{1)*}	=	26.90	-0.20
L3 ¹⁾	=	32.77	
L4	=		
L5	=		
L6	=	47.80	

Hülsenboden

R	=	1.52	
R1	=	11.18	
R3	=		
E	=	2.74	
E1	=	9.00	
e min	=	0.84	
delta	=	40°	
f	=	0.40	
beta	=	35°	

Pulverkammer

P1	=	9.63	
P2 ^{1)*}	=	9.58	-0.20

Schulterkonus

alpha	=	32°31'13"	
S	=	41.40	
r1 min	=		
r2	=		

Hülsenhals

H1*	=	8.46	
H2 ¹⁾	=	8.46	

Geschoss

G1 ¹⁾	=	7.85	
G2	=		
F	=		
L3+G ¹⁾	=	35.84	

Drücke (Energien)**Mech. elektr. Wandler**

Pmax	=	3000 bar	
PK	=	3450 bar	
PE	=	3900 bar	
M	=	17.50	

Verschiedene Daten

Fe ¹⁾	=	0.15	
delta L	=		

PATRONENLAGER MINI**Längen**

L1*	=	25.11	
L2*	=	27.01	
L3 ¹⁾	=	33.07	

Stoßboden

R	=	1.52	
R1	=	11.28	
R2	=		
R3	=		
r	=		

Pulverkammer

E	=	2.72	
P1 ¹⁾	=	9.68	
P2*	=	9.63	

Schulterkonus

alpha ¹⁾	=	32°34'	
S	=	41.59	
r1 max	=		
r2	=		

Hülsenhals

H1*	=	8.52	
H2 ¹⁾	=	8.49	

Geschossübergang

G1 ^{1)*}	=	7.87	
G ^{1)*}	=	3.07	
alpha1	=	90°	
h*	=	0.31	
s	=		
i ¹⁾	=	2°35'35"	
w	=		

Lauf

F ^{1)*}	=	7.62	
Z ¹⁾	=	7.82	

Züge

b	=	4.24	
N	=	4	
u	=	304.80	
Q	=	47.67	mm ²

Maßstab 1:1

Maße in << mm >>
Maße und Toleranzen für Messläufe
siehe Anhang CR 1.

Bemerkungen: 1) Kontrolle aus Sicherheitsgründen
* Grundmaße