

C.I.P.**357 Maximum**

Ursprungsland: US

TAB. IV

Datum 84-06-14

Revision 00-06-07

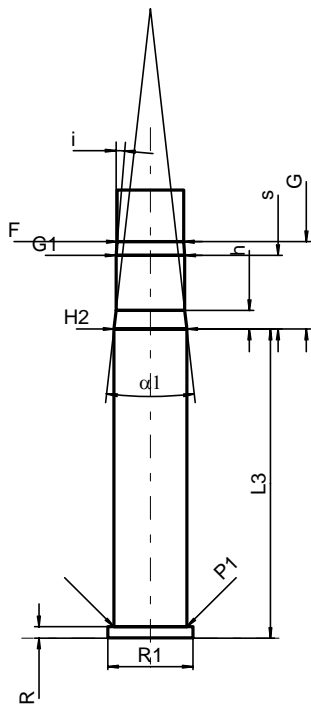
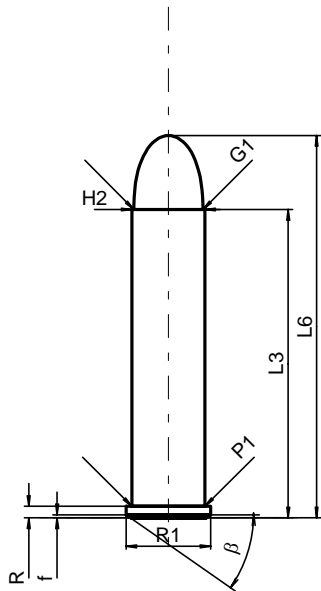

Maßstab 1:1

Maße in << mm >>
Maße und Toleranzen für Messläufe
siehe Anhang CR 1.

PATRONE MAXI**Längen**

L1	=	
L2	=	
L3 ¹⁾	=	40.77
L4	=	
L5	=	
L6	=	50.55

Hülsenboden

R ¹⁾	=	1.52	-0.25
R1	=	11.18	
R3	=		
E	=		
E1	=		
e min	=		
delta	=		
f	=	0.40	
beta	=	35°	

Pulverkammer

P1	=	9.63
P2	=	

Schulterkonus

alpha	=	
S	=	
r1 min	=	
r2	=	

Hülsenhals

H1	=	
H2 ¹⁾	=	9.63

Geschoss

G1 ¹⁾	=	9.12
G2	=	
F	=	
L3+G ¹⁾	=	52.33

Drücke (Energien)**Mech. elektr. Wandler**

Pmax	=	3100 bar
PK	=	3565 bar
PE	=	4040 bar
M	=	25.00

Verschiedene Daten

Fe ¹⁾	=	0.25
delta L	=	

PATRONENLAGER MINI**Längen**

L1	=	
L2	=	
L3 ¹⁾	=	40.89

Stoßboden

R ¹⁾	=	1.52
R1	=	11.28
R2	=	
R3	=	
r	=	

Pulverkammer

E	=	
P1 ¹⁾	=	9.68
P2	=	

Schulterkonus

alpha	=	
S	=	
r1 max	=	
r2	=	

Hülsenhals

H1	=	
H2 ¹⁾	=	9.65

Geschossübergang

G1 ^{1)*}	=	9.09
G ¹⁾	=	11.56
alpha1*	=	13°
h	=	2.46
s	=	9.75
i ^{1)*}	=	4°45'
w	=	

Lauf

F ^{1)*}	=	8.79
Z ¹⁾	=	9.02

Züge

b	=	2.69
N	=	6
u	=	476.00
Q	=	62.57 mm ²

Bemerkungen: 1) Kontrolle aus Sicherheitsgründen
* Grundmaße