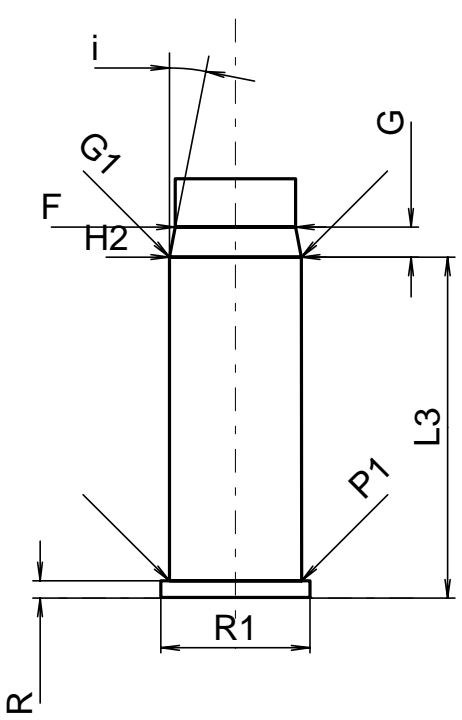

C.I.P.	44 S&W Special (carb) Ursprungsland: US	TAB. IV																																																																																																		
		Datum 84-06-14																																																																																																		
		Revision 95-05-10																																																																																																		
		<table border="0"> <tr> <td style="text-align: center;">PATRONE MAXI</td> <td style="text-align: center;">PATRONENLAGER MINI</td> </tr> <tr> <td>Längen</td> <td>Längen</td> </tr> <tr> <td>L1 =</td> <td>L1 =</td> </tr> <tr> <td>L2 =</td> <td>L2 =</td> </tr> <tr> <td>L3 =</td> <td>L3 ¹⁾ = 30.06</td> </tr> <tr> <td>L4 =</td> <td></td> </tr> <tr> <td>L5 =</td> <td></td> </tr> <tr> <td>L6 =</td> <td></td> </tr> <tr> <td>Hülsenboden</td> <td>Stoßboden</td> </tr> <tr> <td>R =</td> <td>R ¹⁾ = 1.52</td> </tr> <tr> <td>R1 =</td> <td>R1 = 13.16</td> </tr> <tr> <td>R3 =</td> <td>R2 =</td> </tr> <tr> <td>E =</td> <td>R3 =</td> </tr> <tr> <td>E1 =</td> <td>r =</td> </tr> <tr> <td>e min =</td> <td></td> </tr> <tr> <td>δ =</td> <td></td> </tr> <tr> <td>f =</td> <td></td> </tr> <tr> <td>β =</td> <td></td> </tr> <tr> <td>Pulverkammer</td> <td>Pulverkammer</td> </tr> <tr> <td>P1 =</td> <td>E =</td> </tr> <tr> <td>P2 =</td> <td>P1 ¹⁾ = 11.66</td> </tr> <tr> <td></td> <td>P2 =</td> </tr> <tr> <td>Schulterkonus</td> <td>Schulterkonus</td> </tr> <tr> <td>α =</td> <td>α =</td> </tr> <tr> <td>S =</td> <td>S =</td> </tr> <tr> <td>r1 min =</td> <td>r1 max =</td> </tr> <tr> <td>r2 =</td> <td>r2 =</td> </tr> <tr> <td>Hülsenhals</td> <td>Hülsenhals</td> </tr> <tr> <td>H1 =</td> <td>H1 =</td> </tr> <tr> <td>H2 =</td> <td>H2 ¹⁾ = 11.63</td> </tr> <tr> <td>Geschoss</td> <td>Geschossübergang</td> </tr> <tr> <td>G1 =</td> <td>G1 ^{1)*} = 11.63</td> </tr> <tr> <td>G2 =</td> <td>G ¹⁾ = 2.65</td> </tr> <tr> <td>F =</td> <td>α1 [*] =</td> </tr> <tr> <td>L3+G =</td> <td>h =</td> </tr> <tr> <td></td> <td>s =</td> </tr> <tr> <td>Drücke (Energien)</td> <td>i ^{1)*} = 11°6'</td> </tr> <tr> <td></td> <td>w =</td> </tr> <tr> <td></td> <td>Lauf</td> </tr> <tr> <td></td> <td>F ^{1)*} = 10.59</td> </tr> <tr> <td></td> <td>Z ¹⁾ = 10.90</td> </tr> <tr> <td></td> <td>Züge</td> </tr> <tr> <td></td> <td>b = 3.26</td> </tr> <tr> <td></td> <td>N = 5</td> </tr> <tr> <td></td> <td>u = 508.00</td> </tr> <tr> <td></td> <td>Q = 90.65 mm²</td> </tr> <tr> <td></td> <td>Verschiedene Daten</td> </tr> <tr> <td></td> <td>Fe ¹⁾ = 0.15</td> </tr> <tr> <td></td> <td>delta L =</td> </tr> </table>	PATRONE MAXI	PATRONENLAGER MINI	Längen	Längen	L1 =	L1 =	L2 =	L2 =	L3 =	L3 ¹⁾ = 30.06	L4 =		L5 =		L6 =		Hülsenboden	Stoßboden	R =	R ¹⁾ = 1.52	R1 =	R1 = 13.16	R3 =	R2 =	E =	R3 =	E1 =	r =	e min =		δ =		f =		β =		Pulverkammer	Pulverkammer	P1 =	E =	P2 =	P1 ¹⁾ = 11.66		P2 =	Schulterkonus	Schulterkonus	α =	α =	S =	S =	r1 min =	r1 max =	r2 =	r2 =	Hülsenhals	Hülsenhals	H1 =	H1 =	H2 =	H2 ¹⁾ = 11.63	Geschoss	Geschossübergang	G1 =	G1 ^{1)*} = 11.63	G2 =	G ¹⁾ = 2.65	F =	α1 [*] =	L3+G =	h =		s =	Drücke (Energien)	i ^{1)*} = 11°6'		w =		Lauf		F ^{1)*} = 10.59		Z ¹⁾ = 10.90		Züge		b = 3.26		N = 5		u = 508.00		Q = 90.65 mm ²		Verschiedene Daten		Fe ¹⁾ = 0.15		delta L =
PATRONE MAXI	PATRONENLAGER MINI																																																																																																			
Längen	Längen																																																																																																			
L1 =	L1 =																																																																																																			
L2 =	L2 =																																																																																																			
L3 =	L3 ¹⁾ = 30.06																																																																																																			
L4 =																																																																																																				
L5 =																																																																																																				
L6 =																																																																																																				
Hülsenboden	Stoßboden																																																																																																			
R =	R ¹⁾ = 1.52																																																																																																			
R1 =	R1 = 13.16																																																																																																			
R3 =	R2 =																																																																																																			
E =	R3 =																																																																																																			
E1 =	r =																																																																																																			
e min =																																																																																																				
δ =																																																																																																				
f =																																																																																																				
β =																																																																																																				
Pulverkammer	Pulverkammer																																																																																																			
P1 =	E =																																																																																																			
P2 =	P1 ¹⁾ = 11.66																																																																																																			
	P2 =																																																																																																			
Schulterkonus	Schulterkonus																																																																																																			
α =	α =																																																																																																			
S =	S =																																																																																																			
r1 min =	r1 max =																																																																																																			
r2 =	r2 =																																																																																																			
Hülsenhals	Hülsenhals																																																																																																			
H1 =	H1 =																																																																																																			
H2 =	H2 ¹⁾ = 11.63																																																																																																			
Geschoss	Geschossübergang																																																																																																			
G1 =	G1 ^{1)*} = 11.63																																																																																																			
G2 =	G ¹⁾ = 2.65																																																																																																			
F =	α1 [*] =																																																																																																			
L3+G =	h =																																																																																																			
	s =																																																																																																			
Drücke (Energien)	i ^{1)*} = 11°6'																																																																																																			
	w =																																																																																																			
	Lauf																																																																																																			
	F ^{1)*} = 10.59																																																																																																			
	Z ¹⁾ = 10.90																																																																																																			
	Züge																																																																																																			
	b = 3.26																																																																																																			
	N = 5																																																																																																			
	u = 508.00																																																																																																			
	Q = 90.65 mm ²																																																																																																			
	Verschiedene Daten																																																																																																			
	Fe ¹⁾ = 0.15																																																																																																			
	delta L =																																																																																																			
 <p>Maßstab 1.5:1</p>																																																																																																				
<p>Maße in << mm >> Maße und Toleranzen für Messläufe siehe Anhang .</p>	<p>Bemerkungen: 1) Kontrolle aus Sicherheitsgründen * Grundmaße</p>																																																																																																			