

C.I.P.**21 Sharp**

TAB.

V

Datum

24-05-14

Revision

1

Ursprungsland: US

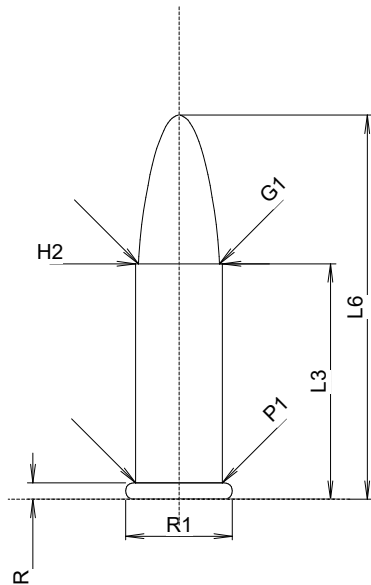
**PATRONE MAXI****Längen**

L1	=	
L2	=	
L3 ¹⁾	=	15.57
L4	=	
L5	=	
L6	=	25.40

Hülsenboden

R ¹⁾	=	1.09	-0.18
R1	=	7.06	
R3	=		
E	=		
E1	=		
e min	=		
δ	=	0°	
f	=		
β	=	0°	

Pulverkammer

P1	=	5.74
P2	=	

Schulterkonus

α	=	
S	=	
r1 min	=	
r2	=	

Hülsenhals

H1	=	
H2	=	5.74

Geschoss

G1 ¹⁾	=	5.35
G2	=	
F	=	
L3+G ¹⁾	=	21.10

Drücke (Energien)**Mech. elektr. Wandler**

Pmax	=	1700 bar
PK	=	1955 bar
PE	=	2210 bar
M	=	9.00

Verschiedene Daten

Fe ¹⁾⁴⁾	=	0.20
delta L	=	

PATRONENLAGER MINI**Längen**

L1	=	
L2	=	
L3 ¹⁾	=	15.93

Stoßboden

R ¹⁾	=	1.09
R1	=	7.32
R2	=	
R3	=	
r	=	0.13

Pulverkammer

E	=	
P1 ¹⁾	=	5.89
P2	=	

Schulterkonus

α	=	
S	=	
r1 max	=	
r2	=	

Hülsenhals

H1	=	
H2 ¹⁾	=	5.79

Geschossübergang

G1 *	=	5.36
G	=	5.53
$\alpha 1$	=	90°
h	=	0.22
s	=	2.62
i *	=	1°30'
w	=	

Lauf

F ¹⁾ *	=	5.21
Z ¹⁾	=	5.33

Züge

b	=	1.73
N	=	6
u	=	304.80
Q	=	21.94 mm ²

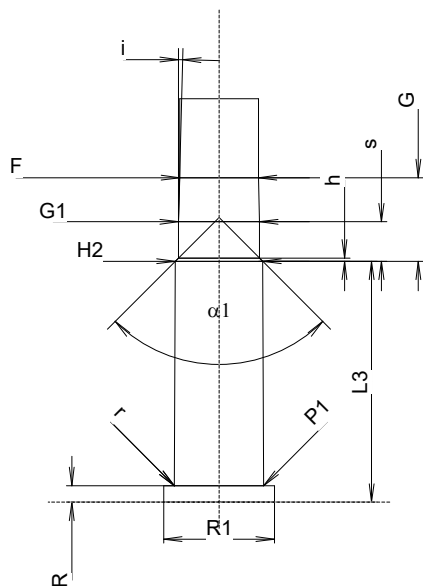

Maßstab 2:1

Maße in << mm >>
Maße und Toleranzen für Messläufe
siehe Anhang CR2.

Bemerkungen:

1) Kontrolle aus Sicherheitsgründen
4) Verschlussabstand an Rand
* Grundmaße