

C.I.P.**9mm Flobert à plombs Metal**

TAB.

V

Date

84-06-14

Revision

00-06-07

Country of Origin: FR

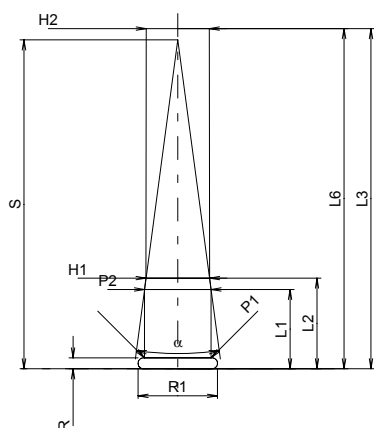
**CARTRIDGE MAXI****Lengths**

L1 *	=	10.50
L2 *	=	12.00
L3 ¹⁾	=	45.00
L4	=	
L5	=	
L6	=	45.00

Case Head

R ¹⁾	=	1.45	-0.18
R1	=	10.50	
R3	=		
E	=		
E1	=		
e min	=		
δ	=		
f	=		
β	=		

Powder Chamber

P1	=	8.80
P2 *	=	8.80

Junction Cone

α	=	15°11'24"
S	=	43.50
r1 min	=	
r2	=	

Collar

H1 *	=	8.40
H2 ¹⁾	=	8.35

Projectile

G1 ¹⁾	=	
G2	=	
F	=	
L1+G ¹⁾	=	12.30

Pressures (Energies)**Method Crusher**

Pmax	=	900 bar
PK	=	1035 bar
PE	=	1170 bar
M	=	12.50

Miscellaneous Dimensions

Fe ¹⁾	=	0.20
delta L	=	

CHAMBER MINI**Lengths**

L1	=	
L2	=	
L3 ¹⁾	=	10.50

Breech

R ¹⁾	=	1.45
R1	=	10.70
R2	=	
R3	=	
r	=	

Powder Chamber

E	=	
P1 ¹⁾	=	8.85
P2	=	

Junction Cone

α	=	
S	=	
r1 max	=	
r2	=	

Collar

H1	=	
H2 ¹⁾	=	8.80

Commencement of Rifling

G1 *	=	8.80
G *	=	1.80
α1	=	
h	=	
s	=	
i	=	6°39'15"
w	=	

Barrel

F ¹⁾ *	=	8.38
Z ¹⁾	=	8.38

Grooves

b	=	
N	=	
u	=	
Q	=	55.15 mm ²

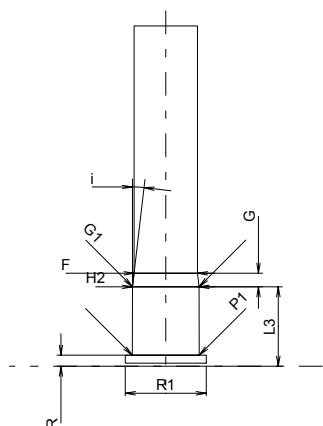

Scale 1:1

Dimensions in << mm >>
Dimensions and Tolerances for Proof Barrels
see Appendix CR 2.

Notes: 1) Check for safety reasons
* Basic dimensions