

C.I.P.**38 SP (9 x 29)**

TAB. VI

Datum 84-06-14

Revision 94-05-31

Ursprungsland: US/IT

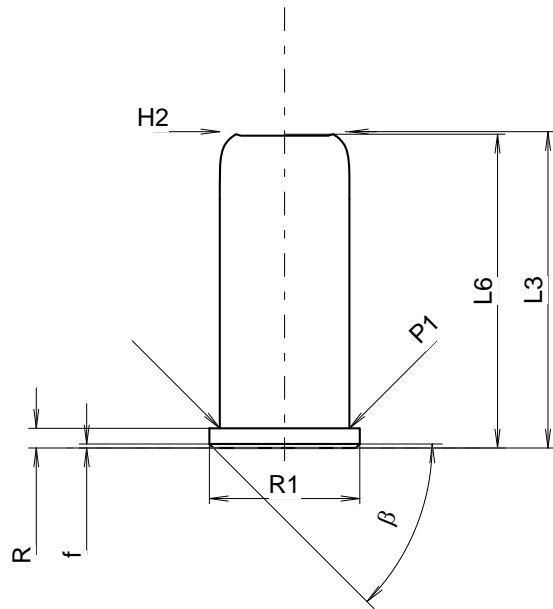
**PATRONE MAXI****Längen**

L1	=	
L2	=	
L3 ¹⁾	=	23.50
L4	=	
L5	=	
L6	=	23.30

Hülsenboden

R	=	1.47
R1	=	11.17
R3	=	
E	=	
E1	=	
e min	=	
δ	=	
f	=	0.30
β	=	45°

Pulverkammer

P1	=	9.62
P2	=	

Schulterkonus

α	=	
S	=	
r1 min	=	
r2	=	

Hülsenhals

H1	=	
H2 ¹⁾	=	9.62

Volumen [cm³]

VC	=	2.18
Va 1	=	0.40
Va 2	=	

Drücke (Energien)**Mech. elektr. Wandler [Va1]**

Pmax	=	3600 bar
PK	=	4140 bar
PE	=	4680 bar
M	=	

Verschiedene Daten

Fe	=	
delta L	=	

PATRONENLAGER MINI**Längen**

L1	=	
L2	=	
L3 ¹⁾	=	24.00

Stoßboden

R ¹⁾	=	1.50
R1	=	11.25
R2	=	
R3	=	
r	=	

Pulverkammer

E	=	
P1	=	9.67
P2	=	

Schulterkonus

α	=	
S	=	
r1 max	=	
r2	=	

Hülsenhals

H1	=	
H2	=	9.65

Geschossübergang

G1 [*]	=	9.00
G	=	
$\alpha 1*$	=	180°
h	=	
s	=	
i	=	
w	=	

Lauf

F [*]	=	9.00
Z	=	9.00

Volumen [cm³]

V(ET)	=	2.24
V(T)	=	

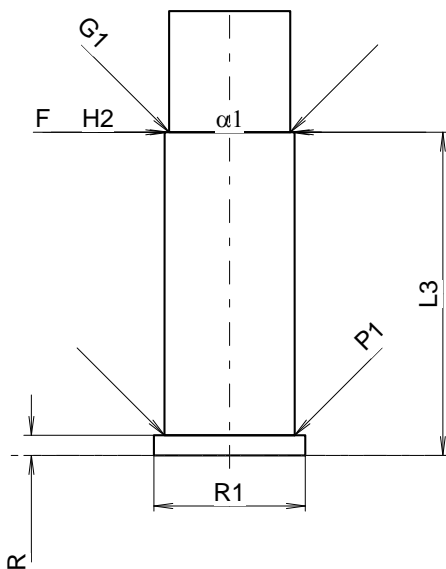

Maßstab 1.78:1

Maße in << mm >>
Maße und Toleranzen für Messläufe
siehe Anhang CR 3.

Bemerkungen: 1) Kontrolle aus Sicherheitsgründen
* Grundmaße