

C.I.P.**5,7/14**

TAB.

VI

Datum

84-06-14

Revision

90-06-13

Ursprungsland: FR

PATRONE MAXI**Längen**

L1	=	
L2	=	
L3 ¹⁾	=	14.20
L4	=	
L5	=	
L6	=	13.50

Hülsenboden

R	=	1.12
R1	=	7.06
R3	=	
E	=	
E1	=	
e min	=	
δ	=	
f	=	
β	=	

Pulverkammer

P1	=	5.74
P2	=	

Schulterkonus

α	=	
S	=	
r1 min	=	
r2	=	

Hülsenhals

H1	=	
H2 ¹⁾	=	5.74

Volumen [cm³]

VC	=	0.37
Va 1	=	0.16
Va 2	=	0.80

Drücke (Energien)**Mechan. elektr. Wandler [Va1]**

Pmax	=	4100 bar
PK	=	4715 bar
PE	=	5330 bar

Mechan. elektr. Wandler [Va2]

Pmax	=	1800 bar
PK	=	2070 bar
PE	=	2340 bar
M	=	

Verschiedene Daten

Fe	=	
delta L	=	

PATRONENLAGER MINI**Längen**

L1	=	
L2	=	
L3 ¹⁾	=	14.30

Stossboden

R ¹⁾	=	1.10
R1	=	7.30
R2	=	
R3	=	
r	=	

Pulverkammer

E	=	
P1	=	5.76
P2	=	

Schulterkonus

α	=	
S	=	
r1 max	=	
r2	=	

Hülsenhals

H1	=	
H2	=	5.76

Übergang

G1 *	=	6.00
G	=	
α1	=	180°
h	=	
s	=	
i	=	
w	=	

Lauf

F *	=	6.00
Z	=	6.00

Volumen [cm³]

V(ET)	=	0.39
V(T)	=	

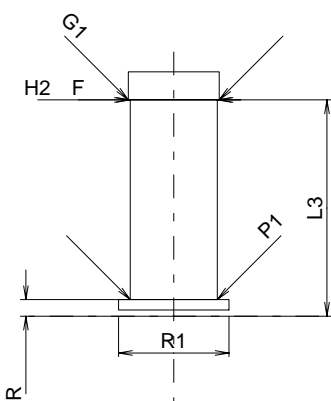
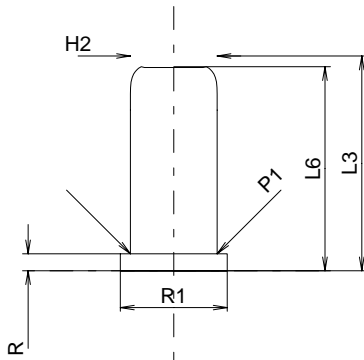

Maßstab 2:1

Maße in << mm >>
Maße und Toleranzen für Messläufe
siehe Anhang CR 3.

Bemerkungen: 1) Kontrolle aus Sicherheitsgründen
* Grundmaße