

C.I.P.**6,3/10**

TAB.

VI

Datum

84-06-14

Revision

90-06-13

Ursprungsland: DE/IT

PATRONE MAXI**Längen**

L1	=	
L2	=	
L3 ¹⁾	=	10.80
L4	=	
L5	=	
L6	=	10.30

Hülsenboden

R	=	1.25
R1	=	7.60
R3	=	
E	=	
E1	=	
e min	=	
δ	=	
f	=	
β	=	

Pulverkammer

P1	=	6.32
P2	=	

Schulterkonus

α	=	
S	=	
r1 min	=	
r2	=	

Hülsenhals

H1	=	
H2 ¹⁾	=	6.32

Volumen [cm³]

VC	=	0.26
Va 1	=	0.16
Va 2	=	0.80

Drücke (Energien)**Mechan. elektr. Wandler [Va1]**

Pmax	=	3200 bar
PK	=	3680 bar
PE	=	4160 bar

Mechan. elektr. Wandler [Va2]

Pmax	=	1600 bar
PK	=	1840 bar
PE	=	2080 bar
M	=	

Verschiedene Daten

Fe	=	
delta L	=	

PATRONENLAGER MINI**Längen**

L1	=	
L2	=	
L3 ¹⁾	=	11.00

Stossboden

R ¹⁾	=	1.25
R1	=	7.70
R2	=	
R3	=	
r	=	

Pulverkammer

E	=	
P1	=	6.35
P2	=	

Schulterkonus

α	=	
S	=	
r1 max	=	
r2	=	

Hülsenhals

H1	=	
H2	=	6.35

Übergang

G1*	=	6.00
G	=	
α1	=	180°
h	=	
s	=	
i	=	
w	=	

Lauf

F*	=	6.00
Z	=	6.00

Volumen [cm³]

V(ET)	=	0.37
V(T)	=	

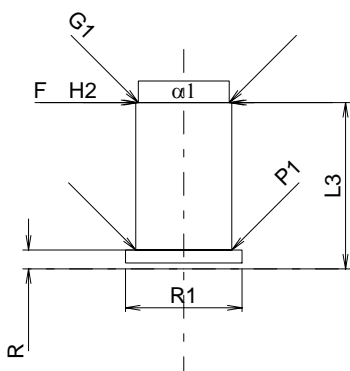
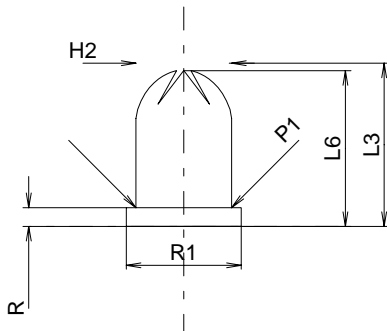

Maßstab 2:1

Maße in << mm >>
Maße und Toleranzen für Messläufe
siehe Anhang CR 3.

Bemerkungen: 1) Kontrolle aus Sicherheitsgründen
* Grundmaße