

C.I.P.**6,8/11**

TAB. VI

Date 84-06-14

Country of Origin: DE/IT

Revision 90-06-13

CARTRIDGE MAXI**CHAMBER MINI****Lengths**

L1	=	
L2	=	
L3 ¹⁾	=	11.80
L4	=	
L5	=	
L6	=	11.00

Lengths

L1	=	
L2	=	
L3 ¹⁾	=	12.00

Case Head

R	=	1.45
R1	=	8.50
R3	=	
E	=	
E1	=	
e min	=	
δ	=	
f	=	
β	=	

Breech

R ¹⁾	=	1.45
R1	=	8.55
R2	=	
R3	=	
r	=	

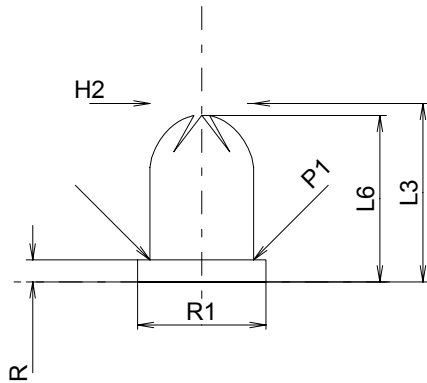
**Powder Chamber**

P1	=	6.86
P2	=	

Powder Chamber

E	=	
P1	=	6.90
P2	=	

Junction Cone

α	=	
S	=	
r1 min	=	
r2	=	

Junction Cone

α	=	
S	=	
r1 max	=	
r2	=	

Collar

H1	=	
H2 ¹⁾	=	6.86

Collar

H1	=	
H2	=	6.90

Volumes [cm³]

VC	=	0.34
Va 1	=	0.16
Va 2	=	0.80

Commencement of Rifling

G1*	=	6.00
G	=	
α1	=	180°
h	=	
s	=	
i	=	
w	=	

Pressures (Energies)**Method Transducer [Va1]**

Pmax	=	3000 bar
PK	=	3450 bar
PE	=	3900 bar

Method Transducer [Va2]

Pmax	=	1550 bar
PK	=	1783 bar
PE	=	2015 bar
M	=	

Barrel

F*	=	6.00
Z	=	6.00

Volumes [cm³]

V(ET)	=	0.48
V(T)	=	

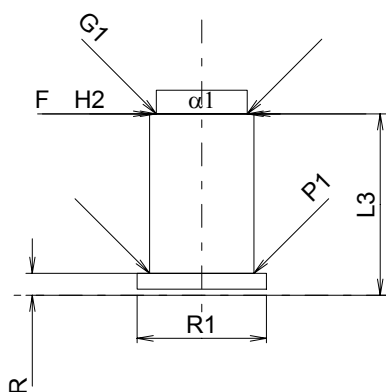

Scale 2:1

Dimensions in << mm >>
Dimensions and Tolerances for Proof Barrels
see Appendix CR 3.

Notes: 1) Check for safety reasons
* Basic dimensions