

C.I.P.	Cal. 8/47,5 mm C.F. Country of Origin: IT	TAB. VII
		Date 04-09-27
		Revision 06-09-19

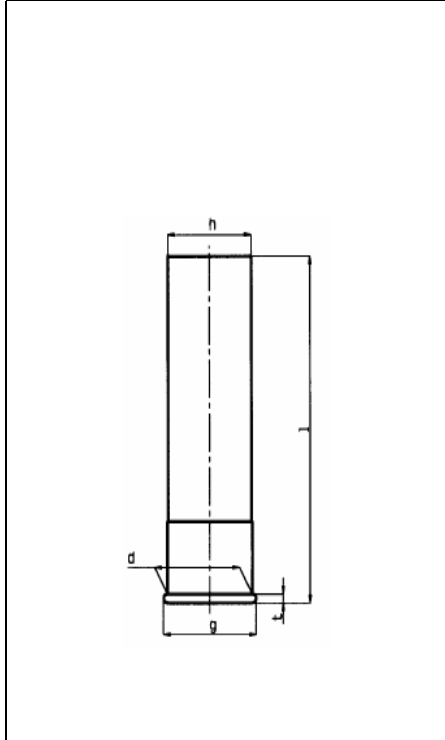

CARTRIDGE MAXIMALE

Dimens. Value Toler.

- d¹⁾ = 9.80 - 0.10
- g = 12.20 - 0.30
- t¹⁾ = 1.45 - 0.20
- h = 9.00 - 0.20
- l = 47.50 - 0.70

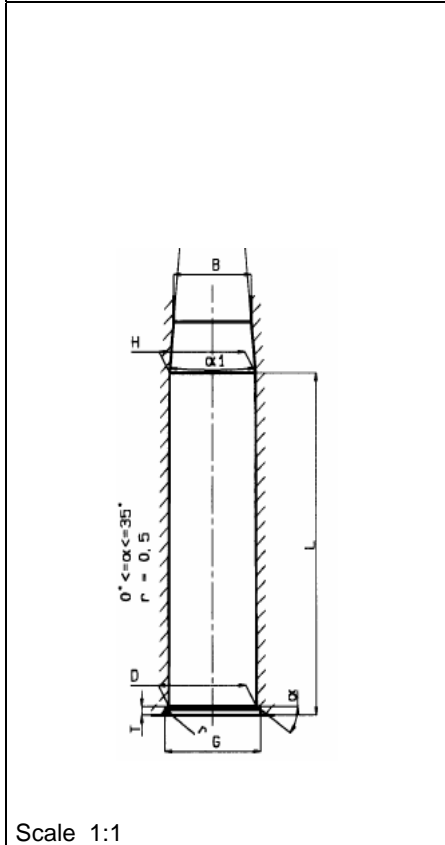

CHAMBER MINIMALE

Dimens. Value Toler.

- D¹⁾ = 9.85 + 0.10
- G = 12.30 + 0.20
- T¹⁾ = 1.45 + 0.10
- H¹⁾ = 9.05 + 0.10
- B¹⁾ = 7.90 + 0.50
- alpha1¹⁾ = 10°30' max
- L¹⁾ = 47.50 + 2.00

Pressure transducer			
Pmax	PK	PE	M
	bar		
830	950	1040	10.5

Headspace

- Fe = 0.10
- Fe¹⁾ = 0.20
- Fe¹⁾ = 0.35

Proof Barrel
with bascule
automatic

Scale 1:1

Dimensions in « mm »
Dimensions et tolerances for Proof Barrels:
See Appendix CR 4.

Notes : 1) Check for safety reasons