

C.I.P.**357 Kraken**

TAB. X

Date 99-11-01

Pays d'origine: CZ

Révision 25-05-13

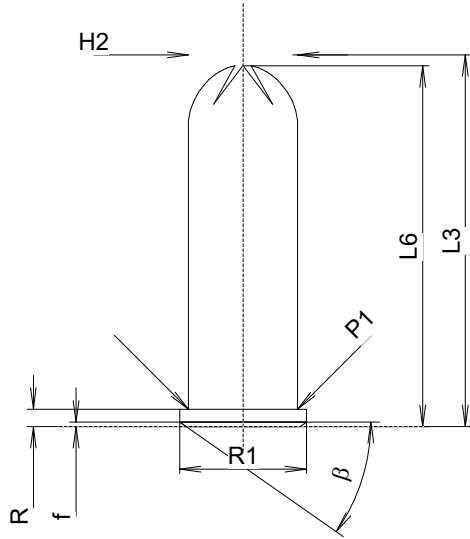
**CARTOUCHE MAXI****Longueurs**

L1	=	
L2	=	
L3 ¹⁾	=	32.77
L4	=	
L5	=	
L6	=	31.80

Culot

R	=	1.52
R1	=	11.18
R3	=	
E	=	
E1	=	
e min	=	
δ	=	0°
f	=	0.40
β	=	35°

Chambre à poudre

P1	=	9.63
P2	=	

Cône de raccordement

α	=	
S	=	
r1 min	=	
r2	=	

Collet

H1	=	
H2 ¹⁾	=	9.63

Projectile

G1	=	
G2	=	
F	=	
L3+G	=	

Pressions (Énergies)**Méthode transducteur**

Pmax	=	3000 bar
PK	=	3450 bar
PE	=	3900 bar
M	=	

Autres indications

Fe	=	
delta L	=	

CHAMBRE MINI**Longueurs**

L1	=	
L2	=	
L3 ¹⁾	=	28.00

Cuvette

R ¹⁾	=	1.52
R1	=	11.28
R2	=	
R3	=	
r	=	

Chambre à poudre

E	=	
P1	=	9.68
P2	=	

Cône de raccordement

α	=	
S	=	
r1 max	=	
r2	=	

Collet

H1	=	
H2	=	9.65

Prise de rayures

G1 *	=	8.80
G	=	
α1	=	59°44'22"
h *	=	0.74
s	=	
i	=	
w	=	

Canon

F *	=	8.80
Z	=	8.80

Rayures

b	=	
N	=	
u	=	
Q	=	mm ²

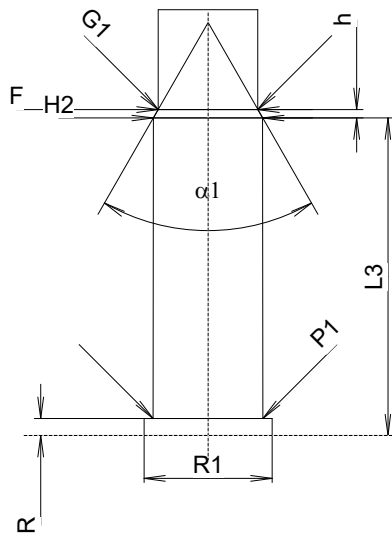

Échelle 1.5:1

Dimensions en << mm >>
Dimensions et tolérances pour les canons
d'épreuve: Voyez Annexe .

Notes: 1) A' contrôler pour la sécurité
* Dimensions de base