

C.I.P.**9 x 20**

TAB.

X

Datum

00-10-06

Revision

25-05-13

Ursprungsland: CZ

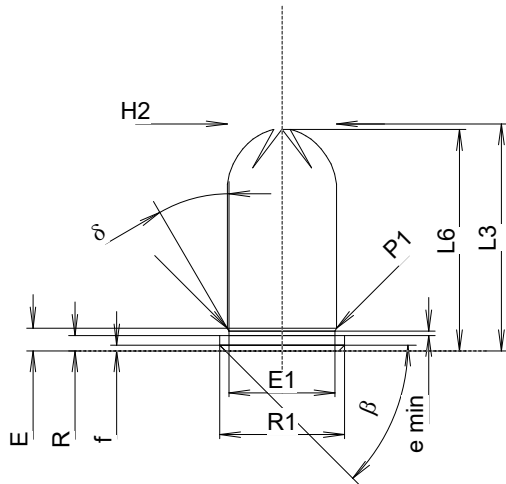
**PATRONE MAXI****Längen**

L1	=	
L2	=	
L3 ¹⁾	=	20.00
L4	=	
L5	=	
L6	=	19.50

Hülsenboden

R	=	1.35
R1	=	11.00
R3	=	
E	=	1.99
E1	=	9.35
e min	=	0.40
delta	=	30°
f	=	0.50
beta	=	45°

Pulverkammer

P1	=	9.63
P2	=	

Schulterkonus

alpha	=	
S	=	
r1 min	=	
r2	=	

Hülsenhals

H1	=	
H2 ¹⁾	=	9.63

Geschoss

G1	=	
G2	=	
F	=	
L3+G	=	

Drücke (Energien)**Mech. elektr. Wandler**

Pmax	=	1000 bar
PK	=	1150 bar
PE	=	1300 bar
M	=	

Verschiedene Daten

Fe	=	
delta L	=	

PATRONENLAGER MINI**Längen**

L1	=	
L2	=	
L3 ¹⁾	=	20.50

Stoßboden

R ¹⁾	=	1.38
R1	=	11.08
R2	=	
R3	=	
r	=	

Pulverkammer

E	=	
P1	=	9.64
P2	=	

Schulterkonus

alpha	=	
S	=	
r1 max	=	
r2	=	

Hülsenhals

H1	=	
H2	=	9.64

Geschossübergang

G1 *	=	10.20
G	=	
alpha1	=	180°
h	=	
s	=	
i	=	
w	=	

Lauf

F *	=	10.20
Z	=	10.20

Züge

b	=	
N	=	
u	=	
Q	=	mm ²

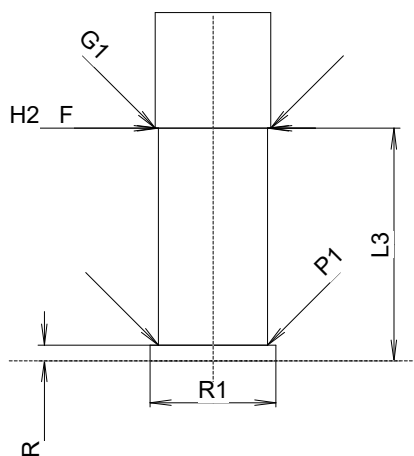

Maßstab 1.5:1

Maße in << mm >>
Maße und Toleranzen für Messläufe
siehe Anhang .

Bemerkungen: 1) Kontrolle aus Sicherheitsgründen
* Grundmaße