

C.I.P.**9 x 27**

TAB. X

Date 00-10-06

Revision 13-05-25

Country of Origin: CZ

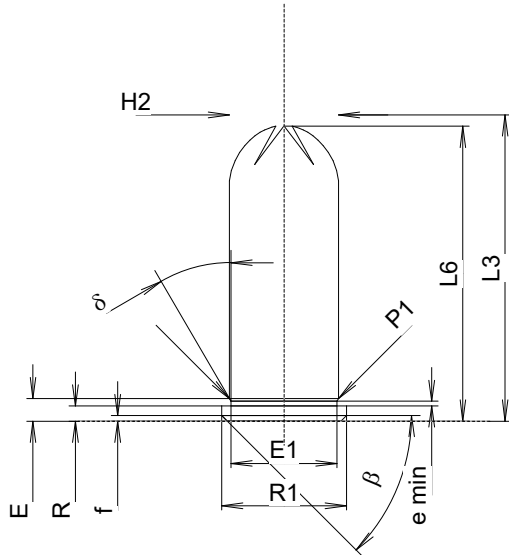
**CARTRIDGE MAXI****Lengths**

L1	=	
L2	=	
L3 ¹⁾	=	27.00
L4	=	
L5	=	
L6	=	26.00

Case Head

R	=	1.35
R1	=	11.00
R3	=	
E	=	1.99
E1	=	9.35
e min	=	0.40
delta	=	30°
f	=	0.50
beta	=	45°

Powder Chamber

P1	=	9.63
P2	=	

Junction Cone

alpha	=	
S	=	
r1 min	=	
r2	=	

Collar

H1	=	
H2 ¹⁾	=	9.63

Projectile

G1	=	
G2	=	
F	=	
L3+G	=	

Pressures (Energies)**Method Transducer**

Pmax	=	3100 bar
PK	=	3565 bar
PE	=	4030 bar
M	=	

Miscellaneous Dimensions

Fe	=	
delta L	=	

CHAMBER MINI**Lengths**

L1	=	
L2	=	
L3 ¹⁾	=	27.00

Breech

R ¹⁾	=	1.25
R1	=	11.20
R2	=	
R3	=	
r	=	

Powder Chamber

E	=	
P1	=	9.65
P2	=	

Junction Cone

alpha	=	
S	=	
r1 max	=	
r2	=	

Collar

H1	=	
H2	=	9.65

Commencement of Rifling

G1 *	=	10.02
G	=	
alpha1	=	180°
h	=	
s	=	
i	=	
w	=	

Barrel

F *	=	10.02
Z	=	10.02

Grooves

b	=	
N	=	
u	=	
Q	=	mm ²

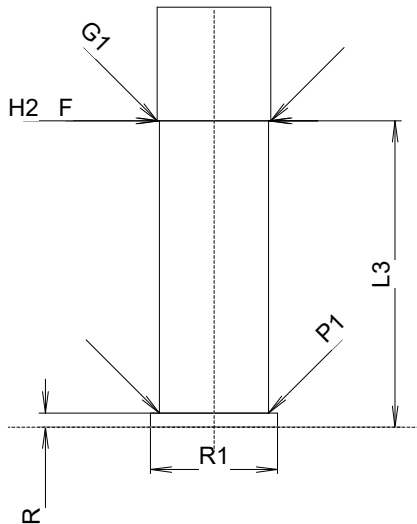

Scale 1.5:1

Dimensions in << mm >>
Dimensions and Tolerances for Proof Barrels
see Appendix CR 3.

Notes: 1) Check for safety reasons
* Basic dimensions