

C.I.P.	MR 35 Punch cal. 12-28,5 Country of Origin: CZ	TAB. X
		Date 96-03-19
		Revision 98-06-09

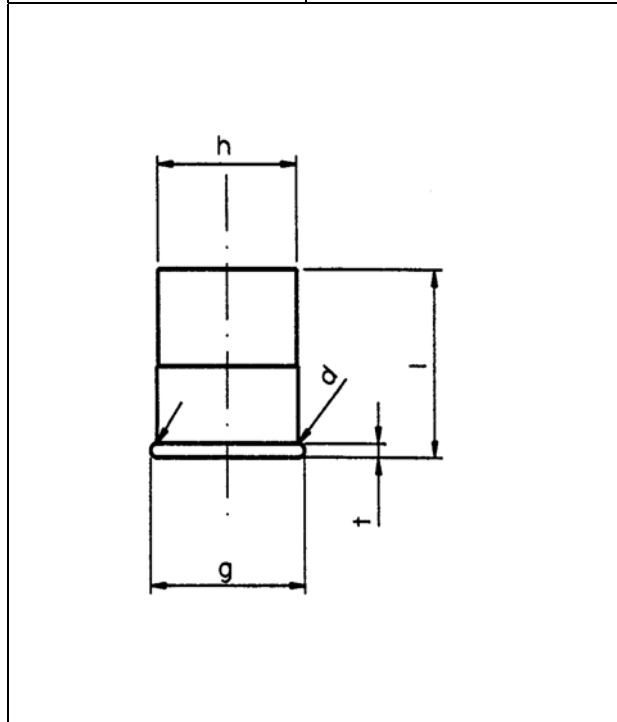

CARTRIDGE MAXIMALE

Dimens. Value Toler.

d ¹⁾	=	20.60	- 0.15
g	=	22.45	- 0.25
t ¹⁾	=	1.88	- 0.25
h	=	20.20	- 0.25
l	=	25.00	- 2.50

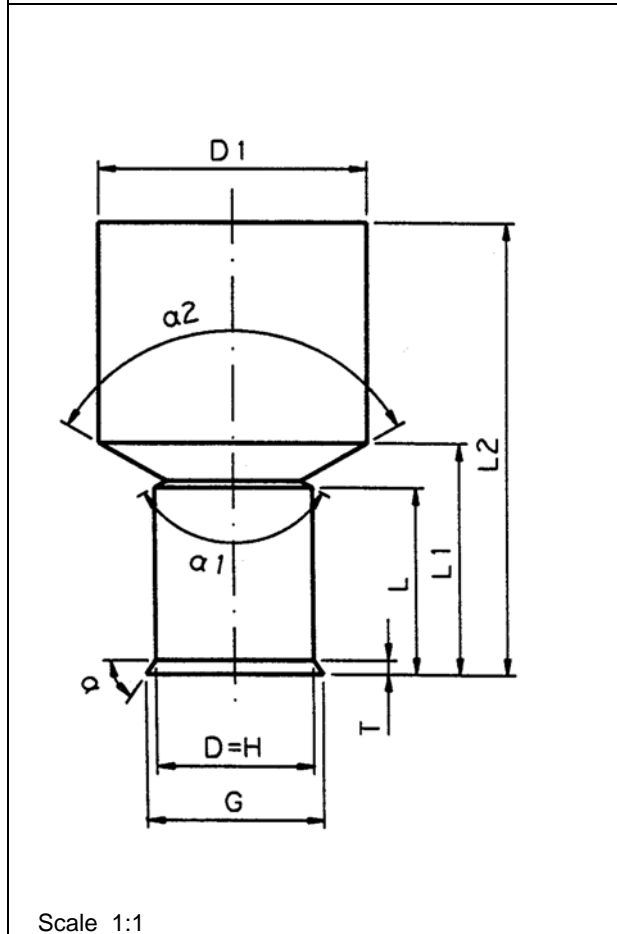

CHAMBER MINIMALE

Dimens. Value Toler.

D ¹⁾ = H	=	20.20	H9
G ¹⁾	=	23.07	
T ¹⁾	=	1.85	+ 0.10
D1 ¹⁾	=	35.00	H11
B ¹⁾	=	44.20	+ 0.70
alpha ¹⁾	=	55°	
alpha1 ¹⁾ = alpha2	=	120°	
L ¹⁾	=	25.00	± 0.10
L1 ¹⁾	=	31.00	± 0.10
L2 ¹⁾	=	60.20	- 0.10

Energy

Emax	EK	EE
	Joule	
150	160	165

Scale 1:1

Dimensions in « mm »
Dimensions and tolerances for Proof Barrels:

Notes : 1) Check for safety reasons