

C.I.P.	MR 35 Punch cal. 15-35 Country of Origin: FR	TAB.	X
		Date	96-02-21
		Revision	98-06-09

CARTRIDGE MAXIMALE

Ammunition ejectable:

reloaded from producer and therefore don't use any case.

CHAMBER MINIMALE

Dimens.	Value	Toler.
D1 ¹⁾	= 15.00	
L1 ¹⁾	= 19.00	
G ¹⁾	= 8.00	
T	= 0.95	+0.10
D3	= 5.85	+0.10
L3	= 6.50	
D2 mini ¹⁾	= 35.00	
L2 ¹⁾	= 60.05	- 0.30
V ¹⁾	= 0.95	- 0.70
H ¹⁾	=	
F mini ¹⁾	= 36.00	
$\alpha 1^{1)}$	=	60°

Energy		
E _{max}	E _K	E _E
	Joule	
115	125	130

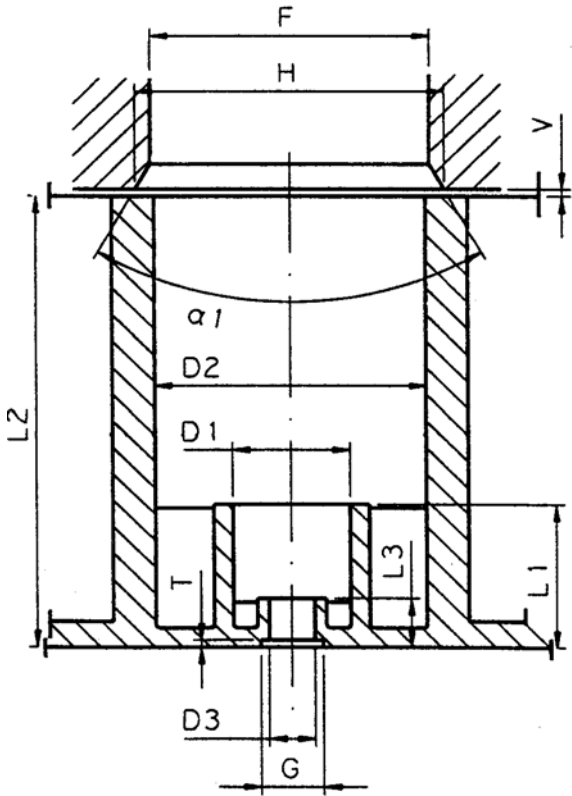

Scale 1:1

Dimensions in « mm »
Dimensions and tolerances for Proof Barrels

Notes : 1) Check for safety reasons