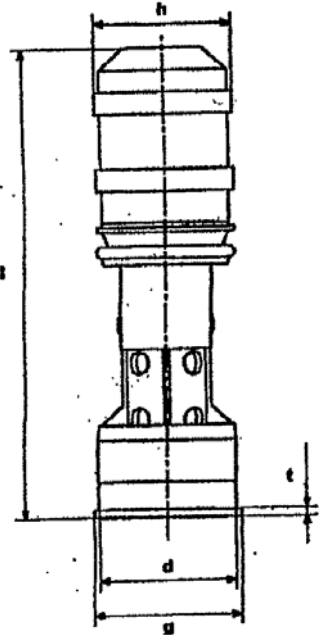
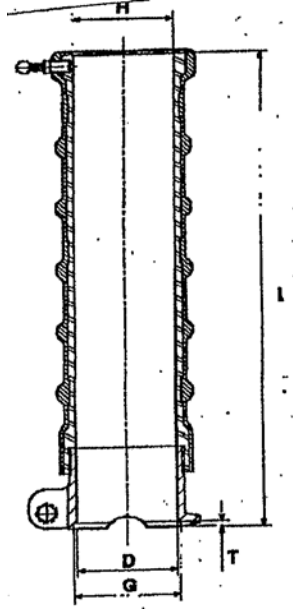

C.I.P.	56 Cougar Pays d'origine : FR	TAB.	X																	
		Date	07-05-14																	
		Révision																		
	CARTOUCHE MAXIMALE																			
	<table border="1"> <thead> <tr> <th>Dimension</th> <th>Valeur</th> <th>Tolérance</th> </tr> </thead> <tbody> <tr> <td>g</td> <td>60</td> <td>-0,1</td> </tr> <tr> <td>d*</td> <td>56,3</td> <td>-0,3</td> </tr> <tr> <td>t*</td> <td>3,5</td> <td>-0,1</td> </tr> <tr> <td>l</td> <td>210,5</td> <td>-1,0</td> </tr> <tr> <td>h</td> <td>55,5</td> <td>-1,0</td> </tr> </tbody> </table>	Dimension	Valeur	Tolérance	g	60	-0,1	d*	56,3	-0,3	t*	3,5	-0,1	l	210,5	-1,0	h	55,5	-1,0	
Dimension	Valeur	Tolérance																		
g	60	-0,1																		
d*	56,3	-0,3																		
t*	3,5	-0,1																		
l	210,5	-1,0																		
h	55,5	-1,0																		
	CHAMBRE MINIMALE																			
	<table border="1"> <thead> <tr> <th>Dimension</th> <th>Valeur</th> <th>Tolérance</th> </tr> </thead> <tbody> <tr> <td>G*</td> <td>60</td> <td>+0,2</td> </tr> <tr> <td>D*</td> <td>56,8</td> <td>+0,1</td> </tr> <tr> <td>T*</td> <td>3,6</td> <td>+0,05</td> </tr> <tr> <td>L*</td> <td>291</td> <td>+2,0</td> </tr> <tr> <td>H*</td> <td>56,7</td> <td>+0,1</td> </tr> </tbody> </table>	Dimension	Valeur	Tolérance	G*	60	+0,2	D*	56,8	+0,1	T*	3,6	+0,05	L*	291	+2,0	H*	56,7	+0,1	
Dimension	Valeur	Tolérance																		
G*	60	+0,2																		
D*	56,8	+0,1																		
T*	3,6	+0,05																		
L*	291	+2,0																		
H*	56,7	+0,1																		
		<table border="1"> <thead> <tr> <th>Energie (Joules)</th> <th>E nominale</th> <th>E max (+10%)</th> </tr> </thead> <tbody> <tr> <td></td> <td>475</td> <td>500</td> </tr> </tbody> </table>		Energie (Joules)	E nominale	E max (+10%)		475	500											
Energie (Joules)	E nominale	E max (+10%)																		
	475	500																		
		Feuillure de l'arme Fe = 0,15 max (manomètre à bascule automatique)																		
Dimensions en « mm » Dimensions et tolérances pour les canons d'épreuve : Annexe CR4		Notes : 1) A contrôler pour la sécurité																		